

USE MANUAL

English

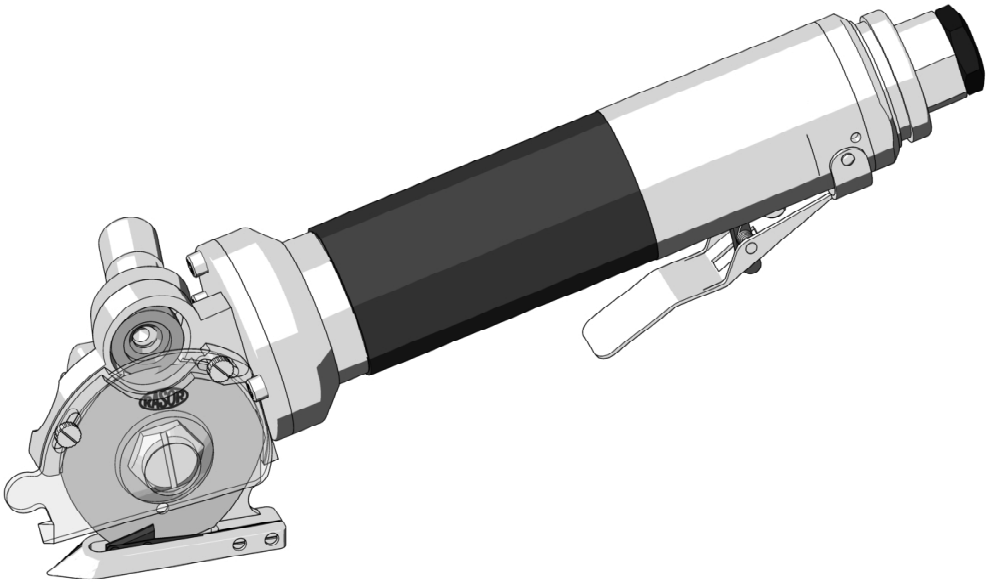

**PNEUMATIC SCISSORS
MOD. FP503**



dal 1946

ED.1-10/13

Rasor® Elettromeccanica S.r.l. was established in Milan in 1946 by Luigi Spinelli. For more than sixty years it has been producing automatic cutting systems, cutting units for textile applications and electric and pneumatic cutters.



Initially considered as a point of reference for cutting systems in the textile applications, the Rasor® products are nowadays widely used in other fields: chemical, automotive, nautical and sport sectors and in furniture manufacturing.

Rasor® can rely on the professional continuity of three generations, thanks to the precious support of the promoting partner, to his passion, dedication and great experience of seventy years.

The main characteristic of Rasor® is that each working phase, starting from the manufacturing of the product up to its packing and delivery is carried out in Rasor® premises by qualified operators who have professionally grown up following the spirit of the company and of its founders. This ensures the high quality which Rasor® has always considered as essential since the beginning of its activity.

Following the innovative spirit mentioned above, our company is constantly focused on the improvement of the product quality, on the study and development of new materials and technologies.

ACKNOWLEDGMENT

Dear Customer,

thank you for choosing a Rasor® Elettromeccanica S.r.l. product.

Rasor® has been a reference point in the field of cutting systems in the textile, clothing, furniture, tailoring, sport, chemical, automotive, nautical and insulating material sectors for years. Its production has always been synonymous with reliability attested by many of satisfied customers.

Rasor® quality system supervises all the company activities in order to provide the Customer with a service that meets its needs and expectations in terms of product quality, delivery reliability and stock of finished products.

All the parts of the devices have been designed and produced to guarantee an optimum performance. In order to keep the high quality level and the long reliability of the Rasor® products, it is recommended using only original spare parts and contacting the head office for any maintenance work.

1. GENERAL SAFETY RULES



This manual is an integral part of pneumatic scissors FP503 and must be carefully read before using it since it gives important indications with regards to its safe installation, use and maintenance. Keep it with care.



Before using pneumatic scissors FP503, read carefully the following general safety rules.

EN
19

- **PACKAGING.**
After taking off the packaging make sure that the machine is intact. In case of doubt do not use them and contact an authorized service centre. Do not leave pieces of packaging (plastic bags, foam polystyrene, boxes, etc.) within the reach of children or disabled persons since they are potential sources of danger.
- **AVOID DANGEROUS ENVIRONMENTS.**
- **KEEP CHILDREN AWAY.**
Unauthorized persons, in particular children, must be kept away from the working area.
- **KEEP THE WORKING AREA ALWAYS IN ORDER.**
The workplace must always be kept in order and well lightened;
- **ALWAYS USE PNEUMATIC SCISSORS FP503 PROPERLY.**
Use the scissors only to carry out the works they have been designed for; do not use them improperly.
- **OBSERVE THE USE OF THE TOOLS.**
Do not cut excessively thick materials and always check blade conditions.
- **AVOID ACCIDENTAL STARTINGS.**
Before connecting pneumatic scissors FP503, make sure that everything is installed properly.
- **CLOTHING.**
Do not use large clothes or accessories that might get stuck in the moving parts.
- **GOGGLES AND PROTECTIVE METAL MESH GLOVES.**
Always use goggles, protective metal mesh gloves approved by Rasor® during use and maintenance operations (according to UNI EN 388:2004 standard).
- **SPARE PARTS.**
During maintenance and replacement operations use only original spare parts. Blade maintenance must be only performed by Rasor® technicians.
- **INSTALLATION.**
Any installation that is not in conformity with these specifications could jeopardize your safety and cancels the warranty.



dal 1946

Informative letter

The installer and the maintenance man must know the content of this manual. Although the main features of the machine described in this manual are not subject to change, **Rasor® Elettromeccanica S.r.l.** reserves the right to modify the components, details and accessories it deems necessary to improve the machine or to meet manufacturing or commercial requirements at any time and without being obliged to update this manual immediately.

EN
20



WARNING



ALL RIGHTS ARE RESERVED ACCORDING TO THE INTERNATIONAL COPYRIGHT CONVENTIONS

The reproduction of any part of this manual, in any form, is forbidden without the prior written authorization of Rasor® Elettromeccanica S.r.l.

The content of this guide can be modified without prior notice. Great care has been taken in collecting and checking the documentation contained in this manual to make it as complete and comprehensible as possible.

Nothing contained in this manual can be considered as a warranty, either expressed or implied - including, not in a restrictive way, the suitability warranty for any special purpose. Nothing contained in this manual can be interpreted as a modification or confirmation of the terms of any purchase contract.

Rasor® Elettromeccanica S.r.l. machines have not been conceived to work in areas at risk of explosions and at high risk of fire.

In case of damage or malfunction, pneumatic scissors FP503 must not be used until the Customer Care Technical Service has repaired them.

Customer Care Technical Service



dal 1946

For any information, please contact
RASOR®ELETTROMECCANICAS.r.l.
Via V. Caldesi, 6; 20161, MILANO (MI) - ITALY
Phone: +39.02.66221231; Fax: +39.02.66221293
e-mail: info@rasor-cutters.com
web: www.rasor-cutters.com

WARNING



The original configuration of the pneumatic scissors must not be changed at all. On receiving the machine make sure the supply corresponds to what has been ordered. In case of non-compliance immediately inform Rasor®. Also make sure the scissors have not been damaged during transport.



dal 1946

2. TRANSPORT AND PACKING

The pneumatic scissors are delivered in a carrying case, inside which there are various options. The code of the ordered product and its serial number are indicated outside the package (see picture 1). The following accessories are contained in a bag inside the package (see picture 2):

- 1) Hexagonal blade (6 sides);
- 2) Grease tube;
- 3) Hexagonal wrench for grinding wheel nut tightening;
- 4) Drift for blade disassembly.
- 5) Lubricating oil (15 ml);
- 6) Rubber hose.

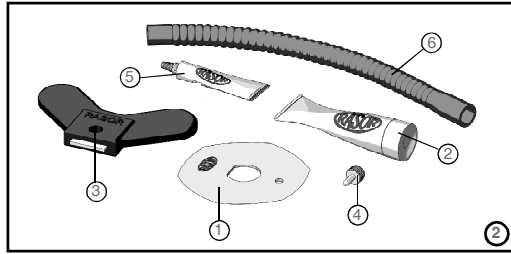
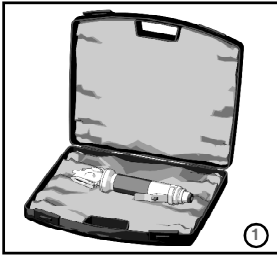

3. PLATE DATA

The manufacturer's identification and 2006/42/EC STANDARD conformity plate (see picture below) is located on the front part of the pneumatic scissors.

The plate must not be removed at all, even if the machine is resold. Always refer to the serial number (written on the plate itself) when contacting the manufacturer. Several safety warnings are printed on a card which is applied to the scissors; such warnings must be strictly followed by everyone dealing with the machine. **The company is not to be held responsible for damage to property or accidents to people which might occur if the above-mentioned warnings are not observed. In such a case, the operator is the only person responsible.**

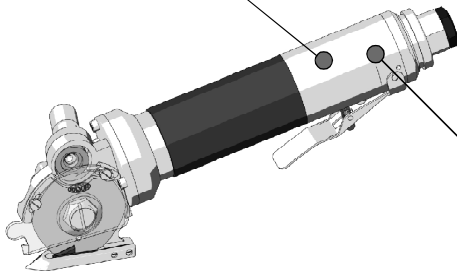
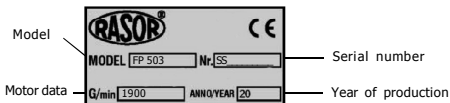

4. PRODUCT DESCRIPTION

This manual describes pneumatic scissors model FP503, which are used in order to quickly cut fabrics in the textile industry and other materials. They are extremely versatile, light and precise in the cutting operation. Thanks to the use of a new foot, the cutting procedure is very quick and effective, even when the bending radius is particularly narrow. One special feature of pneumatic scissors FP503 is their ability to sharpen the blade in each moment without disassembling it by means of a grinding wheel mounted on the scissors head. After carrying out this operation, it is possible to start cutting again. The pneumatic scissors are provided with a threaded connection for many air pipeline. The turbine, perfectly balanced, with a high number of revolutions and totally free of maintenance, reduces the vibrations and the noise to the minimum.

The pneumatic scissors can be used also outdoor and to cut damp or wet materials and therefore particularly recommended in tannery, dyeworks, etc. The pneumatic scissors FP503 are extremely light (they weight only 790g) and handy and allow carrying out quick and precise cuts. The use of compressed air as source of energy allows working continuously without problems of heating or motor overload. The mechanical parts are made up of steel and high resistant bronze and require a lubrication after many working hours.

Device components			
1	1/4" gas connection for the air connector	9	Sharpening button
2	Safety device to enable the control lever	10	Blade protection guard
3	Control lever	11	Motor support
4	Supporting foot	12	Silencer
5	Polygonal blade	13	Antifriction bush
6	Greaser	14	Carbide counterblade
7	Pneumatic motor	15	Reference point
8	Emery grinding wheel	16	Allen screw to disassemble the motor support

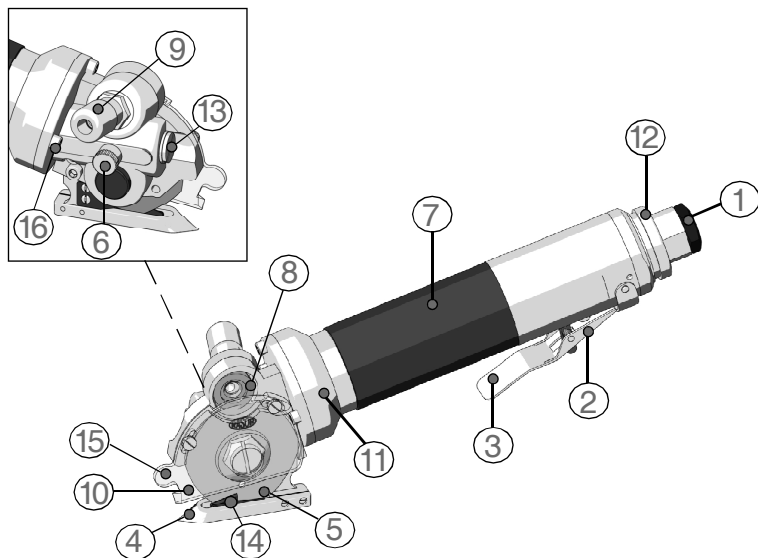

RASOR[®]

dal 1946

5. TECHNICAL FEATURES

Pneumatic scissors FP503 features

Blade diameter	50 mm with counterblade - heavy metal
Blade speed	1.900 rev/min
Cutting working depth	about 8 mm
Power	350 W with max. pressure
Working pressure	6 bar
Weight	790 g
Weight with package	1.600 g
Air consumption	8 litres/sec.
Minimum light for working operations	LUX 200
Vibrations at the start up	< 2,5 m/s ²
Temperature	0 ~ 55 °C
Humidity	10 ~ 95% without condensate

Features of the available blades

503EEXT	EXTRA steel hexagonal blade
503EHSS	HSS steel hexagonal blade
503CHSS	HSS steel circular blade
503EHSSTF	HSS steel hexagonal blade covered with Teflon®
503DHSS	HSS steel decagonal blade

EN
23

The technical data are only indicative and they can be changed without notice.

6. NOISE LEVEL

The maximum acoustic pressure level emitted by pneumatic scissors FP503 is about 60 dB (A). Noise tests have been carried out in compliance with Standard UNI EN ISO 11202:2010. The device noise levels, measured at different distances (without any sound wave filtering system), vary in the extent of few db (A). The noise level has been detected with the silencer supplied with the fixture assembled on the exhaust. The silencer must never be removed.

NOTE

It is advisable for pneumatic scissors FP503 owners to verify the compliance with the standard concerning safety of workers: Italian legislative decree 81/08. The use of ear protecting devices is compulsory.

7. FIELD OF APPLICATION

Pneumatic scissors FP503 have been designed, manufactured and assembled to cut fabrics or technical materials, with the exception of metal, plastic or wood, by means of rotary circular, decagonal or hexagonal blades.

This equipment must not work:

- in areas prone to explosions;
- in presence of fine dust or corrosive gases;
- to cut plastic, metal and wooden materials.

It is forbidden to use pneumatic scissors FP503 for purposes different from the above-mentioned ones.



dal 1946

8. USE WARNINGS

We recommend following the indications below in order to always work in safety conditions.

- All the operations must be carried out complying strictly with the safety rules of the country where the machine is to be installed.
- It is **STRICTLY FORBIDDEN** to smoke during the installation or adjustment operations of the pneumatic scissors.
- The Customer undertakes to comply with and make his staff observe all the rules and regulations in force concerning safety, prevention of accidents and health in the work place. Therefore, the Customer assumes the responsibility to strictly follow all the rules and regulations in force, as well as the special provisions in force in sport and public installations the Customer declares to know after receiving all the relevant necessary information.
- **The pneumatic scissors work even without their safety protective device. This protective device must NEVER be removed.**
- Always check the resistance of the material to be cut and the kind of blade which is being used.
- The Customer shall equip his own personnel with all the individual safety protections for the execution of the works, as well as with the ones which might be prescribed by the Manufacturer due to specific danger conditions of the plant or of the area where the personnel must work.
- Only one operator must use the pneumatic scissors always standing behind the guide handle. Do not make any adjustment while the blade is working.
- Always pay attention to the position of the air pipe to prevent it from being cut or damaged by the blade.
- It is allowed to assemble pneumatic scissors FP503 on machines O.E.M. on condition that their original structure is not modified. Otherwise, the intervention must be certified by Rasor®.
- The pneumatic scissors FP503 are equipped with double safety push button with a lever and a ratchet on the handle: the ratchet prevents the start push button from being enabled accidentally, the lever operates the scissors. Never remove the ratchet.

9. RESIDUAL RISKS

Even though the pneumatic scissors are safe, operators must pay attention to preserve their and other people's safety.

- ⊗ The cutting blade can work even when the protective device is disassembled.

10. USE

To use the pneumatic scissors manually, proceed as follows:

- 1) Lay the material to be cut on the table;
- 2) Connect the air hose to the quick connection "A" (not supplied) (see picture 3);
- 3) Set the pressure gauge (option) to 6 bar;
- 4) Put the material on the cutting foot (see picture 4);
- 5) Push the starting lever after moving the safety device (see picture 5);
- 6) Push the pneumatic scissors in the desired direction, being careful to keep the material in front of them as stretched as possible and preventing it from curling in the front part of the scissors.

NOTE

The thrust on the pneumatic scissors must be as uniform as possible. To carry out linear cuts with precision (and to follow predetermined paths), we also recommend using the arrow point (see point "B" in picture 6).

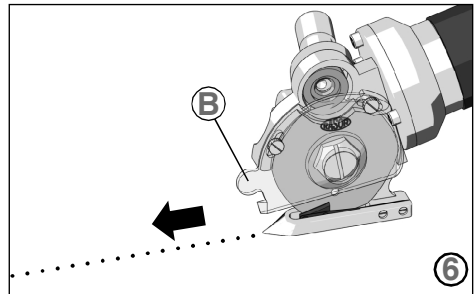
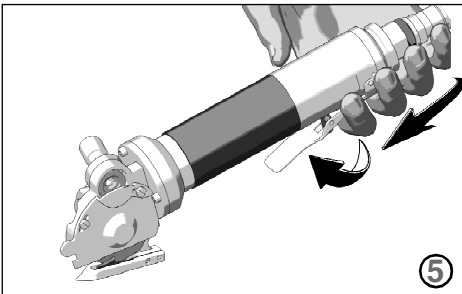
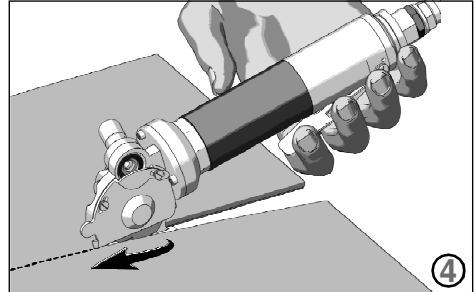
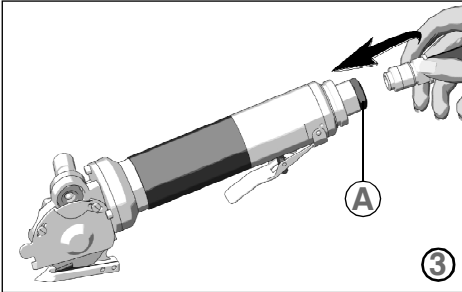

11. AIR PRESSURE GAUGE (OPTION)

The pneumatic scissors must be necessarily fed with lubricated air with a pressure of 4-6 bar.

Rasor® offers, as option, a reduction unit filter with a pressure gauge already calibrated with the quantity of oil to be delivered.

The unit shown in picture 7 is made up of:

- 1 - pressure reducer;
- 2 - valve to drain the condensate;
- 3 - drip-feed oiler unit;
- 4 - oil tank;
- 5 - pressure gauge;
- 6 - condensate tank;
- 7 - pipe fitting to connect the quick connection to the network;
- 8 - pipe fitting to connect the quick connection to the scissors.

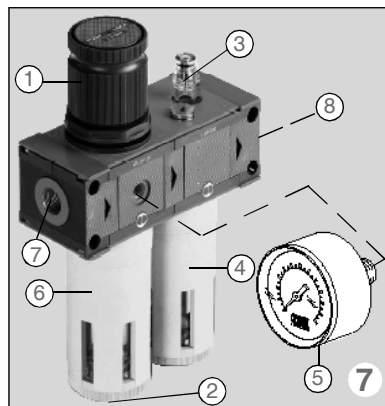

For the use and maintenance read the instruction sheet supplied with the filter.

12. BLADE SHARPENING

After many hours of a continuative use of the pneumatic scissors or if they are not able to cut anymore, it is necessary to sharp the blade.

To carry out this operation, start the blade and press emery grinding wheel "2" on the same one (by pressing sharpening button "1" as shown in picture 8) for 3-4 seconds. Repeat this operation 2-3 times.

If the sharpening process should be ineffective, check the wear of the emery grinding wheel "3" (see picture 9). If wheel "3" is too worn or dirty, replace it by removing the blade by means of the propper tool.

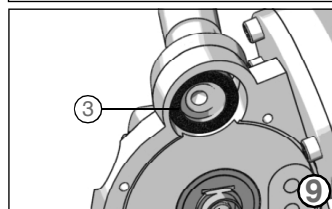
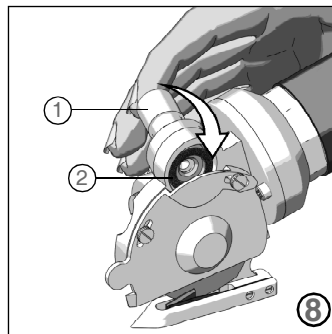

13. LUBRICATION

Every 3-4 working days, it is necessary to lubricate the gear pair. In order to carry out this operation, remove protective plug "A" located on the head of the pneumatic scissors and fill it with the grease supplied. Screw plug "A" again a few turns. Screw plug "A" a few turns every working day (see picture 10) when the machine is used without interruption.

WARNING



The blade must never be dirty with grease or oil.

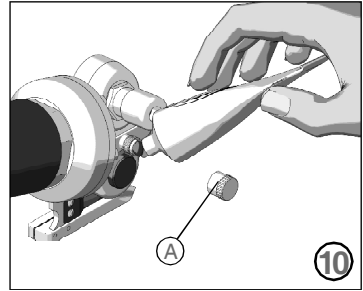

14. BLADE REPLACEMENT

If the blade is no more able to cut (even after repeating the sharpening operation several times) it is necessary to replace it. In order to carry out this operation, use butterfly wrench "1" and drift "3" locking the blade (shown in picture 11). In order to replace the blade, proceed as follows:

- 1) Use some protective gloves in compliance with Italian Legislative Decree 81/08.
- 2) Remove safety protection "B", by unscrewing the two slotted screws "A" by means of a screwdriver (not supplied by the manufacturer), as shown in picture 12.
- 3) Insert drift "3" (see picture 13) into hole "C" in order to lock the blade (the hole in the blade must correspond to the hole in the structure).
- 4) Use butterfly wrench "1" in order to unscrew nut "D" and remove blade "E" (see picture 14).
- 5) Replace the worn blade with the new one "2", being careful to center the blade on the gear, in the correct position, and remember to assemble it with its sharp side (the one with the writing RASOR) positioned towards the external side of the pneumatic scissors.
- 6) Assemble all the components again and carry out some cutting and sharpening tests.

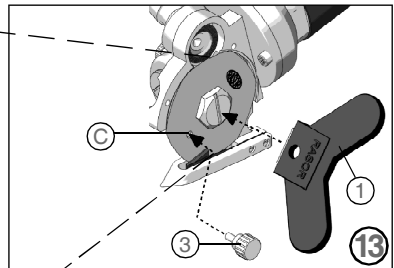
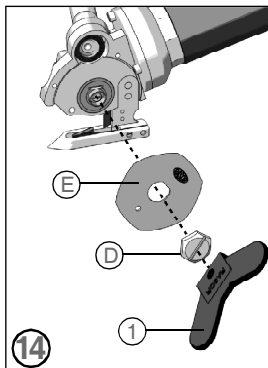
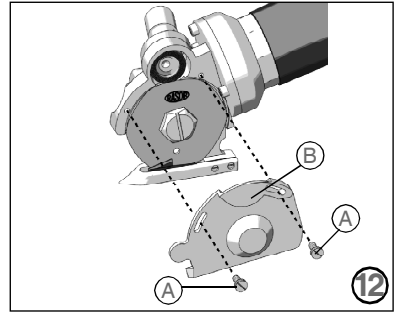
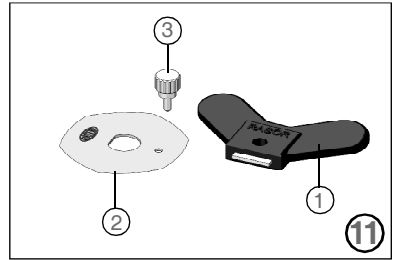

15. TROUBLESHOOTING

✘ PROBLEM

⇒ SOLUTION

The fabric is not cut or it gets stuck between the blade and the counterblade

Check the counterblade integrity

Check the kind of fabric

Sharpen the blade

Check the fabric thickness

Check the compatibility between blade and fabric

Make sure that the turbine turns correctly

Reduce the feeding speed

Carry out the lubrication

The pneumatic scissors are noisy

Disassemble the blade and remove the material residues

Check the silencer

Check the wear of the gear pair

Check the air circuit integrity

The scissors start slowly or work intermittently

Set working pressure at 6 bar

EN
28

16. SPARE PARTS / EXPLODED VIEW

CODE	DESCRIPTION	CODE	DESCRIPTION	CODE	DESCRIPTION	CODE	DESCRIPTION
503EHSS	HEXAGONAL BLADE Ø 50 mm., HSS STEEL	F 5074CPL	COMPLETE EMERY GRINDING WHEEL UNIT	FP085	JOINT	FP86021	SILENCER SEAT O'RING
F 5032	GEAR CROWN CENTRAL PIN	F 5075	EMERY GRINDING WHEEL BUSH	FP086	SHAFT REAR BEARING	FP86022	SILENCER SEAT
F 5033	GREASER CAP	F 5076	WASHER	FP08701	SPACER	FP86025	BRONZE SILENCER-FILTER
F 5034	GREASER	F 5077	SPRING INSIDE THE SHARPENING BUTTON, Ø 6 mm	FP088	SHAFT FRONT BEARING	FP86026	SMALL REDUCTION UNIT O'RING
F 5036	SHIM ADJUSTMENT WASHER	F 5078	SPRING INSIDE THE SHARPENING BUTTON, Ø 9 mm	FP089	COMPENSATOR RING	FP86028	REDUCTION UNIT
F 5037	RING NUT TO FIX THE CROWN BEARING	F 5079	SHARPENING BUTTON	FP092	O-RING	FP8612301	CONTROL HEAD
F 5038	GEAR CROWN BEARING	F 5080	SCREW FIXING THE SHARPENING BUTTON	FP09301	COUPLING SHAFT	FP8612301CPL	COMPLETE CONTROL HEAD
F 5040	GEAR CROWN FIXING SCREW 3,5MA	FP014	MOTOR SUPPORT	FP09301CPL	COMPLETE COUPLING SHAFT	FP86127	NYLON BUSH FOR VALVE
F 5042	RING NUT FIXING THE BLADE	FP015CPL	COMPLETE GEAR CROWN	FP09401	COUPLING FLANGE	FP86130	CONNECTOR 1/4" WITH FILTER
F 5057	BLADE LOCKING DRIFT	FP05001CPL	COMPLETE MOTOR	FP095	HANDLE FOR HOOK	FP86146	COMPLETE CONTROL LEVER
F 5059	BLADE DISASSEMBLY KEY	FP074	REAR FLANGE	FP096	COMPENSATION RING NUT	FRNF503	SET OF ACCESSORIES FP503
F 5065	SCREW FIXING THE FOOT	FP075	REAR FLANGE PLUG	FP86010	PISTON GUIDE	P001	WORM SCREW
F 5066	PLATE LOCKING THE THREADS FASTENING SCREW	FP076	REAR FLANGE BEARING	FP86011	PISTON GUIDE O' RING	P002	SPRING PIN
F 5067	PLATE LOCKING THE THREADS	FP077	POSITION PIN	FP86012	PISTON GUIDE O' RING	P003	ROLL BEARING
F 5068	WIDIA COUNTERBLADE WITH SPRING	FP078	BUCKETS	FP86013	PISTON	P005	SUPPORT FIXING SCREW 4MA
F 5069	SCREW FIXING THE COUNTERBLADE	FP079	CYLINDER	FP86013CPL	COMPLETE PISTON WITH GUIDE	P029	RUBBER HOSE
F 5070	STEEL FOOT	FP080	ROTOR	FP86014	STOP RING	T102906	LEVER AND RATCHET FIXING PIN
F 5070CPL	COMPLETE FOOT	FP080CPL	COMPLETE TURBINE	FP86017	VALVE	T102909	RATCHET FOR LEVER
F 5071	BLADE PROTECTION GUARD	FP081	FRONT FLANGE BEARING	FP86018	VALVE O' RING	T102910	RATCHET SPRING
F 5071/1	SCREW FIXING THE BLADE PROTECTION GUARD	FP082	FRONT FLANGE	FP86019	STEEL BALL	T107900	LUBRICATING GREASER
F 5074	PLATE WITH EMERY	FP08301	MOTOR CASE	FP86020	CONICAL SPRING	T107902	LUBRICATING OIL (15 ml)

ACCESSORIES

CODE	DESCRIPTION	CODE	DESCRIPTION
P171	MALE QUICK COUPLING - 1/4" GAS	P171CPL	MALE QUICK COUPLING - 1/4" GAS (COMPLETE)
P170	FEMALE QUICK COUPLING - 1/4" GAS	P170CPL	FEMALE QUICK COUPLING - 1/4" GAS (COMPLETE)
P169	FLEXIBLE PIPE FITTING Ø 8 mm - 1/4" GAS FEMALE	P174CPL	COMPLETE COUPLING WITH THREAD - 1/4" GAS
		P173	AIR PIPE Ø 8x6 mm



dal 1946

WARRANTY

Rasor® Elettromeccanica S.r.l. pneumatic scissors have a 12 month warranty from the date indicated on the last page of this manual, except in case of different written agreements.

The warranty covers all manufacturing and material defects. Replacement and repair operations are covered only if carried out by our company and at our workshop. If in-warranty goods need to be repaired, **the customer must always send the complete scissors to Rasor®. Single units will not be repaired under warranty.**

The material to be repaired must be sent CARRIAGE FREE.

Once the machine has been repaired, it will be sent CARRIAGE FORWARD to the customer. The warranty covers neither technicians' intervention on site nor the machine disassembly from the installation place.

If for practical reasons, one of our technicians is sent to the premises, the customer will be charged the costs plus the travelling expenses.

The warranty does not include:

- ✎ failure caused by wrong use or assembly,
- ✎ failure caused by external agents,
- ✎ failure caused by lack of maintenance or negligence,
- ✎ blades and parts subject to wear.
- ✎ failure caused by dirty compressed and/or not lubricated air.

WARRANTY FORFEITURE:

- ✎ In case of arrearage or other breaches of contract,
- ✎ Whenever changes or repairs are carried out on our pneumatic scissors without our prior authorization,
- ✎ Whenever the serial number is tampered with or cancelled,
- ✎ Whenever the damage is caused by improper use, bad treatment, bumps, falls and other causes not due to normal working conditions,
- ✎ Whenever the unit seems tampered with, dismantled or previously repaired by unauthorized staff,
- ✎ In case the pneumatic scissors are used for purposes that are different from the ones described in this manual.
- ✎ In case non-original spare parts are used.

All repair operations carried out under warranty do not interrupt its duration.

All disputes will be settled in the court of justice of Milan (Italy).

We thank you in advance for the attention you will pay to this manual and we invite you to inform us of any change you deem necessary to improve it and make it more complete.

DECLARATION OF CONFORMITY



We hereby certify that the machine specified hereunder complies to the requirements of Machinery Directive 2006/42/EC and to technical rulings UNI EN 414:2002, UNI EN ISO 12100:2010.

Noise tests have been carried out according to UNI EN ISO 11202:2010 Standards.

Pneumatic scissors FP503 have been produced according to workmanlike standards.

We declare that the above-mentioned goods comply with the standards in force concerning safety and hygiene at work that can be applied to the material itself (refer to the Local Law).

- 1. Category: **PNEUMATIC SCISSORS**
- 2. Manufacturer: **RASOR®ELETTROMECCANICA S.R.L.**
- 3. Type: **FP503**
- 4. Serial number:
- 5. Year of manufacture:
- 6. Manufactured in: **ITALY**
- 7. Additional information:

Warranty expiration:
12 months from the date of invoice or receipt

RASOR ELETTROMECCANICA S.R.L.
CUTTING EQUIPMENTS



(Signature)



