



1946

CORDLESS ELECTRIC CUTTER

NERAPRO



USE AND MAINTENANCE INSTRUCTIONS

Please read this manual carefully before using the device and keep it safe with the product.

TRANSLATION OF ORIGINAL AND COMPLETE INSTRUCTIONS

MEANING OF WARNING AND DANGER SYMBOLS

Safety instructions, which must be followed to prevent physical harm, are identified by the following symbols:



CAUTION HAZARD

Indicates operations that can cause generic injuries or trigger malfunctions or damage to the equipment and/or materials if not carried out correctly; particular attention and adequate preparation are therefore required.



CAUTION ELECTRICAL HAZARD

Indicates operations that can cause electrical injuries or trigger malfunctions or damage to the equipment and/or materials if not carried out correctly; particular attention and adequate preparation are therefore required.



DO NOT

Indicates PROHIBITED operations.

INDEX

1 GENERAL INFORMATION	3
1.1 Important safety information	3
1.1.1 General warnings	3
1.2 Prohibitions	4
1.3 Handling and storage	4
1.4 Limits of use	4
1.5 Technical specifications	4
1.6 Noise	4
1.7 Limitation of liability	4
1.8 Identification data	4
1.9 Package contents	5
1.9.1 Information on batteries	5
1.10 Description of the device	5
2 USE.....	6
2.1 Manual mode	6
2.2 Charging the batteries	6
3 MAINTENANCE	7
3.1 Blade sharpening	7
3.2 Lubrication	7
3.3 Replacing the blade	7
3.3.1 Available blades	8
4 TROUBLESHOOTING	9
4.1 Problems and possible causes/solutions	9
5 SPARE PARTS.....	10
6 DISPOSAL	11
6.1 Disposal at end of life	11
7 WARRANTY	11

EC - DECLARATION OF CONFORMITY

PRODUCT MANUFACTURED BY:

RASOR ELETTROMECCANICA S.r.l.

Via Giannetto Mattei, 41/43 - 20044 Arese- (MI) - ITALY

Model: NERAPRO

Rasor Elettromeccanica s.r.l. declares, under its own responsibility, that the aforementioned products, to which this declaration refers, comply with the Directives on the approximation of the laws of EEC member states relating to:

- Machinery 2006/42/EC;
- Electromagnetic Compatibility 2014/30/EU
- RoHS Directive 2011/65/EU

Milan, 01/06/2022.



Mr Lorenzo Spinelli
CEO

GENERAL INFORMATION

1 GENERAL INFORMATION

1.1 Important safety information

1.1.1 General warnings

- The product user must store the following instructions carefully and follow them closely, as improper use of the device can harm people or damage the product or property, exempting **Rasor Elettromeccanica S.r.l.** from any liability.
- The following instructions must be kept with the product to which they refer and be stored in a place where users can access and view them.
- Reproduction, in whole or in part, of the illustrations or text given in these instructions is prohibited. **Rasor Elettromeccanica S.r.l.** reserves the right to amend the documentation without prior notice.



CAUTION HAZARD

It is particularly important to keep the product out of reach of children and pets.
 The product must be used indoors, away from heat, wet and humidity.
 The product must be cleaned solely with a dry cloth, after having disconnected it from the power source.
 During normal work operations, do not wear loose-fitting clothing or accessories that may be a source of risk.
 Wear metal mesh safety gloves and safety goggles during the normal work cycle.
 Materials must be perfectly dry when using the product.



CAUTION HAZARD

The product must be started and used solely in compliance with all safety guidelines given in these instructions. Failure to follow these instructions, or any product alteration not carried out by our authorised technicians, will void the warranty and relieve the manufacturer of any liability arising from harm to people, damage to property or to the product itself.



CAUTION HAZARD

The cordless electric cutter also works without a safety guard. This guard must NEVER be removed.
 Metal parts may be hot after use.



CAUTION HAZARD

Check that electrical and mechanical parts are in excellent working order before starting the device.
 Children must not play with the product.
 Cleaning and maintenance intended to be carried out by the user must not be carried out by unsupervised children.
 Use only original spare parts supplied by Rasor Elettromeccanica S.r.l.
 Any required operation (maintenance or repair) must be carried out by qualified personnel after having cut the power supply, thus preventing accidental start-up which could cause harm to people or property. Switching the product off is not sufficient.
 Users must follow the accident-prevention regulations in force in their country and must use adequate protection when using and maintaining the product.

1.2 Prohibitions



DO NOT

- The product and its electrical or mechanical connections MUST NOT be tampered with or modified.
- It is FORBIDDEN to remove parts of the product.
- It is FORBIDDEN to use the product in areas at risk of explosion and/or fire.
- It is FORBIDDEN to use the product or accessories with wet hands. Risk of electrocution.

1.3 Handling and storage

The product must be stored in its original packaging and in a dry, covered location away from heat sources, dirt and humidity. The product can be stored between 0° and 55°C.

1.4 Limits of use

All Rasor Elettromeccanica products are tested before being shipped to the customer to guarantee safe and long-lasting operation.

The product must be used solely for its intended purpose. Any other use is forbidden and constitutes a risk.

The product operates at a maximum temperature of 55°C.

The protection rating of the device is IP 65.

1.5 Technical specifications

Model	NERAPRO
Blade diameter	50 mm, with carbide fixed blade
Blade supplied	50EEXT, 6-sided, Steel EXTRA
Blade speed	1000 revs/min
Cutting capacity	approx. 9 mm
Motor power	DC 3.7V - 35W
Battery	3.7 V Li-Ion®, 2.4 Ah rechargeable
Weight (with battery)	580 g
Total weight (with packaging)	950 g
Minimum brightness for use	200 LUX
Start-up vibration	< 2,5 m/s ²
Usage temperature	0 - 55° C
Usage humidity	10%-95% without condensation

1.6 Noise

The maximum sound pressure level emitted is approximately 60 dB (A). Airborne noise was detected in compliance with EN ISO 15744:2008. The noise levels emitted by the device at various detection distances (with no soundwave filtration system) vary by a few db (A).

1.7 Limitation of liability

The manufacturer declines all liability for any damage and malfunctions arising from:

- failure to follow the instructions given in this manual
- repairs not carried out in a workmanlike manner (the use of non-original spare parts and accessories can adversely affect product operation)
- damage caused by arbitrary changes by the user or by unauthorised interventions
- failure to carry out maintenance as indicated
- power supply faults
- damage or defects caused by improper use
- use by untrained or unauthorised personnel
- damage or defects caused by failure to follow use and maintenance instructions.

1.8 Identification data

A nameplate (1) stating the product data is applied to the NERAPRO. Ensure the nameplate has been applied to the product; if not, inform the manufacturer and/or retailer immediately. Devices without the nameplate must not be used, or the manufacturer's liability will be voided.



Sample nameplate

GENERAL INFORMATION

1.9 Package contents

The cutter is supplied with batteries and a charger in a cardboard box (A). The product code and serial number are specified on the outer packaging.

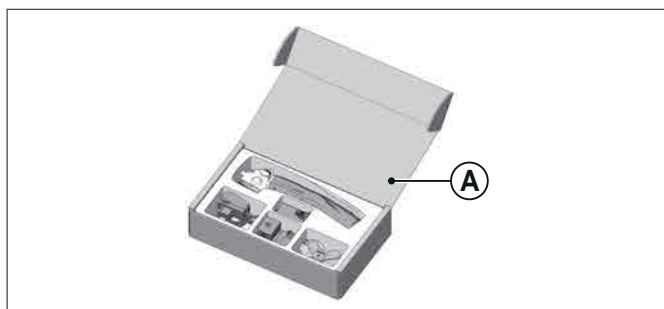

The following accessories are also included:

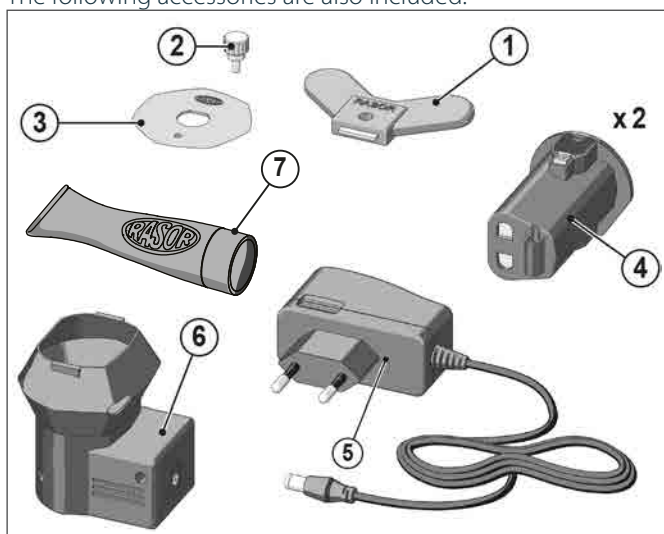

- 1 Butterfly key for removing blade nut
- 2 Blade assembly/disassembly punch
- 3 6-sided blade
- 4 Rechargeable battery 3.7 V with Li-ion® technology (x2)
- 5 Standard charger with European or American plug
- 6 Docking station for recharging 3.7 V batteries with Li-ion technology
- 7 Tube of lubricating grease

1.9.1 Information on batteries

Following a few simple guidelines extends the lifespan of the batteries supplied:

- charge the battery fully before using it for the first time
- recharge when it is almost flat (approximately 10-20% charge remaining). The battery cells can be recharged up to 200 times
- avoid letting the battery go completely flat or overcharging it
- recharge at room temperature (+18/21°C)
- do not leave the battery in direct sunlight
- if not used for a prolonged period, store the battery with approximately 50% charge remaining at a room temperature of 5/10°C
- recharge at least every 12 months.

1.10 Description of the device

The **NERAPRO** cordless electric cutter has been designed, built and assembled for cutting fabrics and all kinds of materials – **EXCEPT FOR** metals, plastic and wood – using a rotary blade. The equipment must not be used:

- in environments with explosive atmospheres;
- in the presence of fine dust or corrosive gases;
- for cutting plastic, metal or wood materials.

Any use of the NERAPRO cordless electric cutter for purposes other than those indicated above is prohibited and constitutes a hazard.

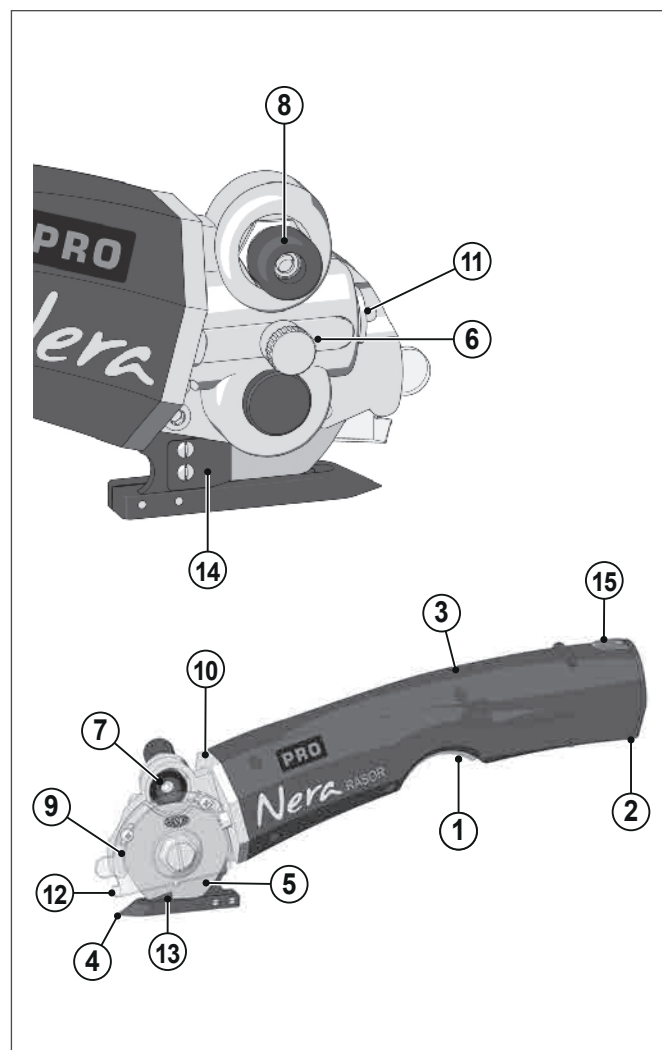

- | | |
|-------------------------|---|
| 1 Start button | 9 Blade protection case |
| 2 Li-ion 3.7V battery | 10 Motor support |
| 3 Plastic motor housing | 11 Worm regulator |
| 4 Steel base | 12 Guide tip |
| 5 Polygonal steel blade | 13 Carbide fixed blade |
| 6 Greaser | 14 Wire clip |
| 7 Emery wheel | 15 Top and bottom buttons for disconnecting battery |
| 8 Sharpener button | |

2 USE

2.1 Manual mode

To use the cordless electric cutter manually:

- Disconnect the battery from the charger (if charged) as described in section 2.2;
- Attach the battery to the motor, fitting it as indicated on the battery itself;
- Lay out the material on a table;
- Position the material above the cutting base;
- Press the button under the handle to start the cutter;
- Push the cordless electric cutter in the direction of the required cut, while keeping the material taut to avoid it curling up in the front part of the cutter.

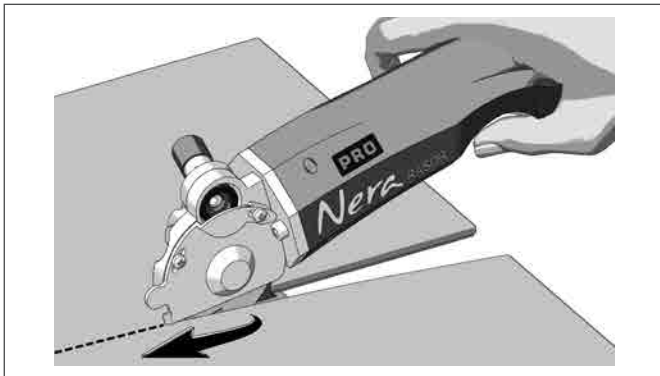

- To cut neatly along a pre-marked line, we recommend using the tip (1) as a guide.

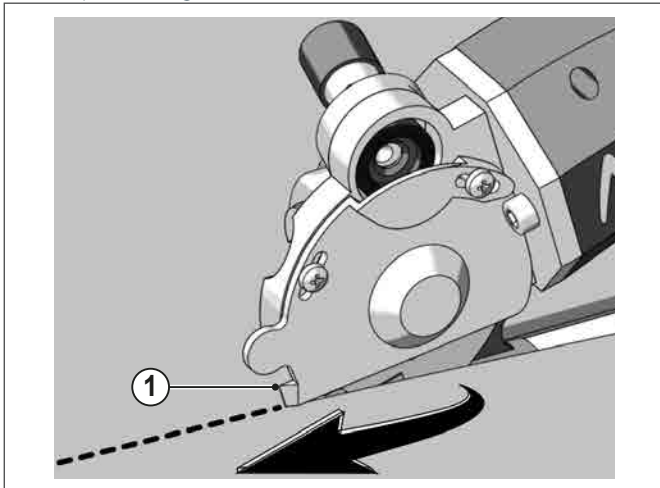

WARNINGS



Apply pressure uniformly to the cordless electric cutter.

2.2 Charging the batteries



CAUTION

Always check the charger voltage against the mains voltage for the country of use.

When the battery is flat, recharge it using the docking station supplied with the device only.

The docking station must be connected to the standard charger (with European or American plug) also supplied with the cutter.

Release the battery (1) from the motor by pressing the orange buttons (2) above and below the battery, then insert it in the docking station (3).

Never use batteries other than the one supplied (rechargeable 3.7 V with Li-ion® technology).

You can check the charge level on the docking station and charger:

- battery charging (red)
- battery fully charged (green)

Using the standard CH36 charger (European plug) or CH3601 (American plug) charger, the battery takes approximately 4 hours to charge fully.

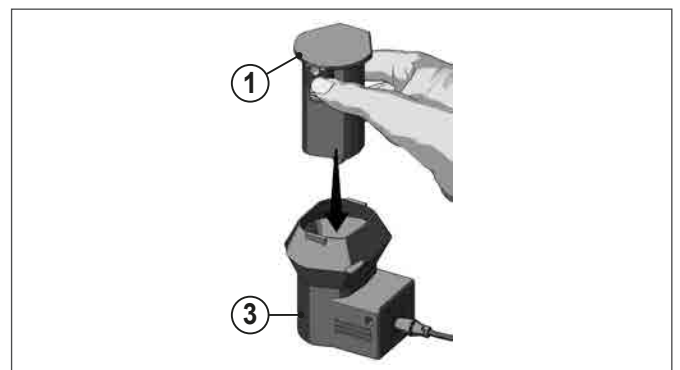
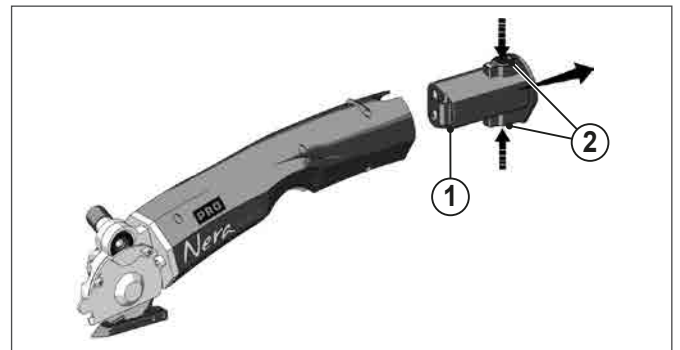

CAUTION

Only ever use the charger supplied (100-240VAC, 50/60 Hz, 0.4A max - Output: 4.2V, 2A).

MAINTENANCE

3 MAINTENANCE

3.1 Blade sharpening

After several hours of continuous use, or if the cutter is no longer cutting as it should, sharpen the blade.

To sharpen the blade, start the cutter then press and hold the sharpening button (1) for 3-4 seconds.

Repeat 2-3 times.

If sharpening the blade is not effective, check the emery wheel (2) for wear.

If the emery wheel (2) is excessively worn or dirty, replace the wheel. To do this, first remove the blade using the appropriate tool.

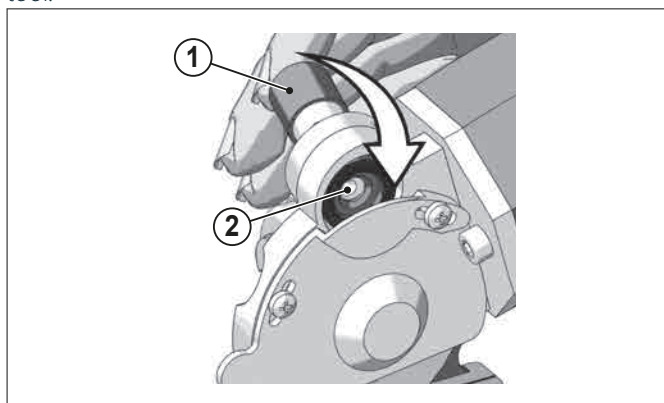

3.2 Lubrication

Lubricate the pair of gears every 3-4 days of use.

To do this, remove the protective cap (1) on the cutter head and fill with grease (supplied).

Turn the cap (1) a few times to screw it back on.

Tighten the cap (1) by a few turns every day the cutter is used.

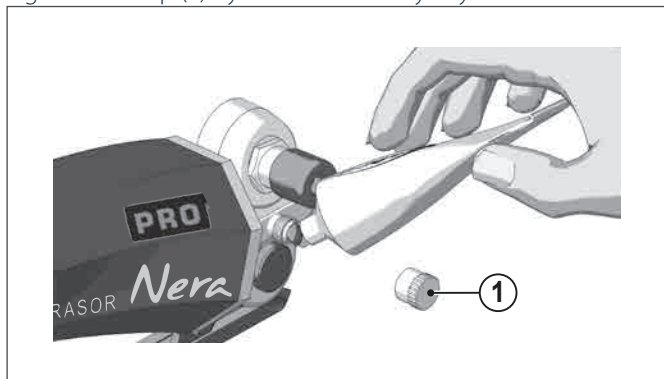

CAUTION



The blade must never be dirty with grease or oil.

3.3 Replacing the blade

If the blade no longer cuts the material (even after repeated sharpening), replace it.

To do this you need the butterfly key (1) and blade-locking punch (2).

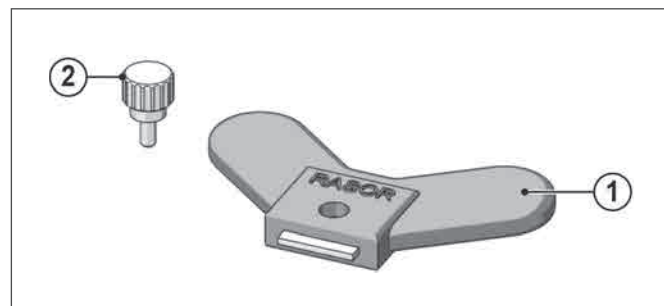

To replace the blade:

- 1 Disconnect the battery from the tool;
- 2 Wear protective gloves in accordance with Italian Legislative Decree 81/08;
- 3 Unscrew the two slotted screws (4) using a screwdriver (not supplied by the manufacturer) and remove the safety guard (3);

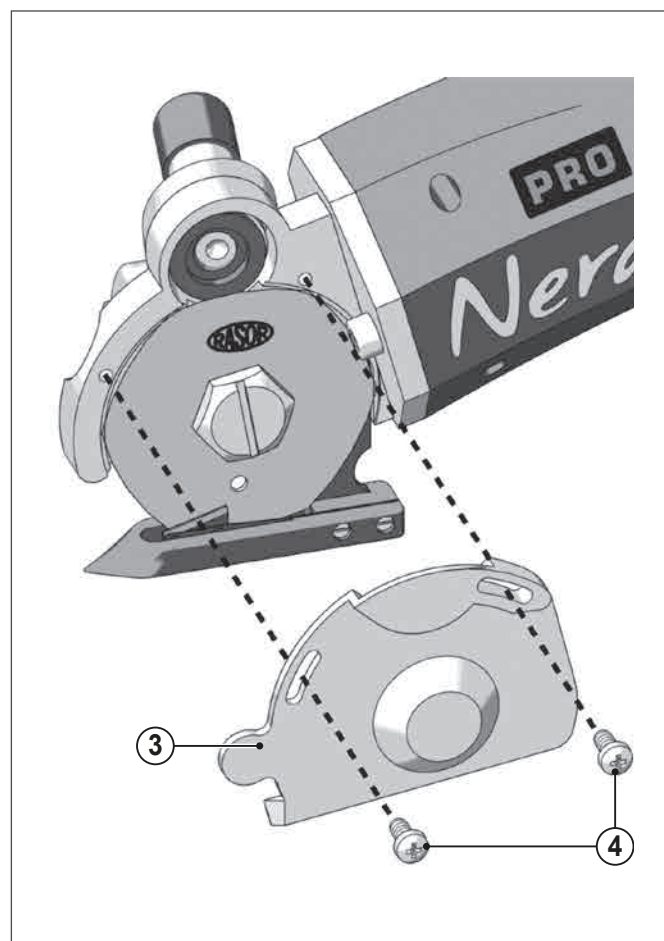

- 4 Insert the punch (2) in the hole (5) to lock the blade (the hole in the blade must line up with the hole in the stand);

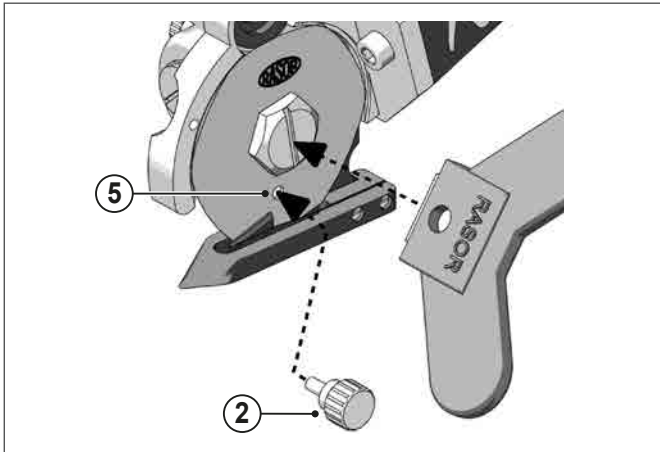

Use the butterfly key (1) to unscrew the nut (6) and remove the blade (7);

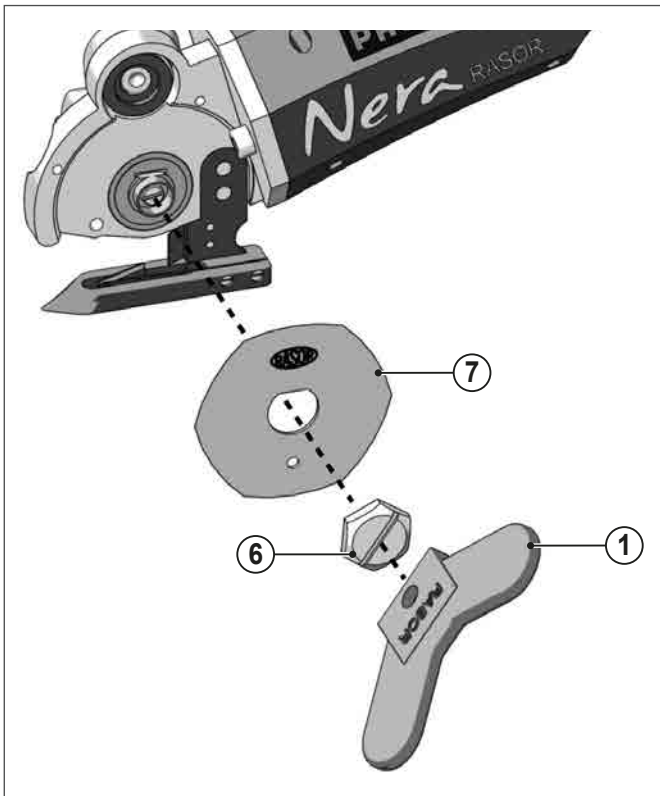

- 5 Replace the worn blade with a new one (8) of the same size and with the same specifications. Make sure the blade is centred on the gear in the correct position. Fit the blade with the sharp side (the side with the word Rasor on it) facing outwards away from the cutter;

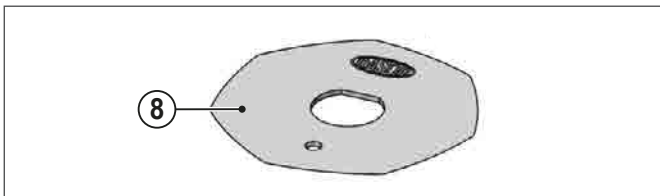

- 6 Refit all parts and test both cutting and sharpening.

3.3.1 Available blades

CODE	DESCRIPTION
503EEXT	6-sided EXTRA steel blade
503EHSS	6-sided HSS steel blade
503CHSS	HSS circular steel blade
503DHSS	10-sided HSS steel blade
503DHSSTF	10-sided HSS steel blade coated with Teflon®
503EHSSTF	6-sided HSS steel blade coated with Teflon®

Technical data are indicative and subject to change without notice.

TROUBLESHOOTING

4 TROUBLESHOOTING

4.1 Problems and possible causes/solutions

ANOMALY	SOLUTION
The textile is not cut or gets stuck between the blade and the fixed blade	Check that the blade and fixed blade are touching and that there is no residual material on the fixed blade Check that the fixed blade is integral Check the type of textile Sharpen the blade Check the textile thickness Check compatibility between the blade and the fabric Check the motor turns correctly Check the battery charge level Reduce the speed
The cutter is noisy	Lubricate Dismantle the blade and remove residual material
The cutter is slow to start, works on and off, or does not start	Check the batteries are inserted correctly Check the plastic joint is integral Check the battery charge level



WARNINGS

Contact the retailer for problems not included in this table

5 SPARE PARTS

WARNINGS



Use only original spare parts to replace faulty components.

When requesting spare parts, always state the exact model name and the device's serial number.

CODE	DESCRIPTION
503EEXT	6-SIDED BLADE, 50 mm, EXTRA STEEL
BA 011	MOTOR FLANGE
BA 012	ELECTRIC MOTOR WITH REDUCER
BA 012CPL	FULL NERA504 MOTOR
BA 013	RIGHT-HAND PLASTIC MOTOR COVER
BA 014	LEFT-HAND PLASTIC MOTOR COVER
BA 015	MOTOR COVER FIXING SCREW
BA 016	PLASTIC BUTTON
BA 017	BUTTON SPRING
BA 018	POWER BUTTON
BA 019	CONTACT TERMINALS
BA 020	REDUCER FLANGE FIXING SCREW
BA 021	NERA MOTOR MOUNT FIXING SCREW
F 5027	JOINT
F 5029	GREASE SCREW BEARING 5x11x4
F 5029/1	CORRUGATED WASHER
F 5029/2	SEEGER RING
F 502901	GEAR SCREW BEARING 5x13x4
F 503101	GEAR SCREW REGULATOR
F 5032	GREASE GEAR WHEEL CENTRAL PIN
F 5033	GREASER CAP
F 5034	GREASER
F 5036	SPACER
F 5037	GEAR WHEEL BEARING FIXING RING NUT
F5038	GREASE GEAR WHEEL BEARING
F 5040	GEAR WHEEL FIXING SCREW

CODE	DESCRIPTION
BAT36	3.7V, 2400 mA Li-Ion® BATTERY
DK36	DOCKING STATION
CH36	100-240 V CHARGER EU PLUG
CH3601	100-240 V CHARGER US PLUG

DO NOT



Use unsuitable spare parts. They can cause anomalous operation and harm people or property.

CODE	DESCRIPTION
F 5042	BLADE FIXED RING NUT
F 5057	BLADE LOCKING PUNCH
F 5059	BLADE DISMANTLING KEY
F 5065	BASE FIXING SCREW
F 5066	WIRE CLIP FIXING SCREW
F 5067	WIRE CLIP
F 5068	CARBIDE FIXED BLADE WITH SPRING
F 5069	FIXED BLADE FIXING SCREW
F 5070	STEEL BASE
F 5070CPL	COMPLETE BASE
F 5071	BLADE PROTECTION CASE
F 5071/1	BLADE GUARD FIXING SCREW
F 5074	DISC WITH EMERY
F 5074CPL	COMPLETE SHARPENER
F 5075	SHARPENER BUSH
F 5076	WASHER
F 5077	SHARPENER SPRING Ø6mm
F 5078	SHARPENER SPRING Ø9mm
F 5079	SHARPENER BUTTON
F 5080	SHARPENER BUTTON FIXING SCREW
F 5082	GEAR WORM
F 5082CPL	COMPLETE WORM
F 5083CPL	COMPLETE GEAR WHEEL
F 5084CPL	COMPLETE MOTOR MOUNT
F 5084SET	COMPLETE CUTTING PART
FRNN504	COMPLETE SET OF NERA ACCESSORIES

WARNINGS



For an exploded diagram of spare parts with item codes, visit www.razor-cutters.com

DISPOSAL

6 DISPOSAL

6.1 Disposal at end of life

CAUTION



Some parts of the product may contain polluting or hazardous substances that, if leaked, could harm the environment and human health.

PRODUCT CONFORMING TO EU DIRECTIVE 2012/19/EU on waste electrical and electronic equipment (WEEE).

The crossed out wheeled bin symbol on the equipment or its packaging indicates that the product must be collected separately from other waste at the end of its life.

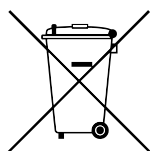

As such, the user must take the product at the end of its life to a suitable centre for recycling electrical and electronic waste.

Separate collection enables the decommissioned equipment to be properly recycled, treated and disposed of whilst preventing harm to the environment and to health and facilitating the reuse and/or recycling of the device's component materials.

Spent batteries must be disposed of according to current regulations.

CAUTION



Existing local regulations may impose heavy penalties for improper disposal of this product.

7 WARRANTY

Rasor® Elettromeccanica S.r.l. cordless electric scissors are covered by a 12-month warranty from the manufacture date, barring other written agreement.

The warranty covers all material and manufacturing defects and envisages the replacement of spare parts or the repair of defective parts solely by us at our workshop.

If returning the product to us for repair, the customer must always send the complete scissors to Rasor®. Individual defective parts will not be accepted for repair under warranty.

Material for repair must be sent CARRIAGE PAID.

Once repaired, the device will be returned to the customer CARRIAGE FORWARD.

The warranty does not cover our technicians working on the customer's premises or dismantling the product.

If one of our technicians has to be sent out for practical reasons, labour will be charged at current rates plus travel expenses.

THE WARRANTY DOES NOT COVER:

- faults caused by incorrect use or assembly;
- faults caused by external agents;
- faults caused by neglect or poor maintenance;
- normal wear and tear on the blades and products.

THE WARRANTY IS VOIDED:

- in the event of delinquency or other breach of contract;
- if repairs or changes are made to our cordless electric scissors without our consent;
- if the serial number is tampered with or erased;
- if damage is caused by improper use or poor treatment, e.g. knocks, falls or other causes not attributable to normal operating conditions;
- if the device is dismantled, tampered with or repaired by personnel not authorised by Rasor® Elettromeccanica S.r.l.;
- if the cordless electric scissors are used for purposes other than those stated in this manual;
- if parts other than Rasor® original spare parts are used.

Repairs made under warranty do not interrupt its duration.

The competent court for all disputes is the court of Milan.

RASOR ELETTROMECCANICA SRL

Via Giannetto Mattei 41/43

20044 Arese (MI) · Italy

ph. +39 02 66 22 12 31

info@rasor-cutters.com

www.rasor-cutters.com

FOLLOW US:

