

USE MANUAL

English

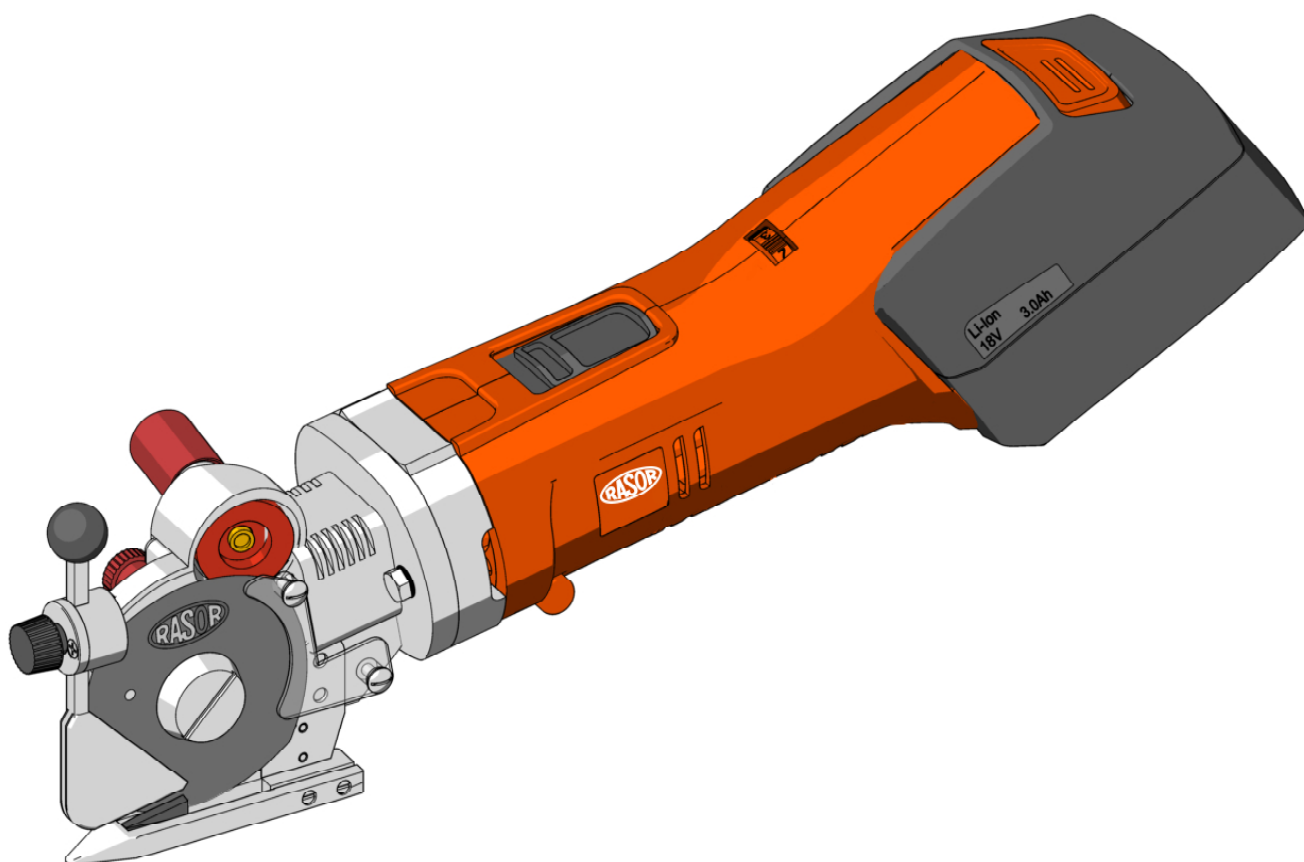

BATTERY SCISSORS
MOD. TT703 TurfTrimmer

RASOR®
dal 1946



Rasor® Elettromeccanica S.r.l. was established in Milan in 1946 by Luigi Spinelli. For more than sixty years it has been producing automatic cutting systems, cutting units for textile applications and electric and pneumatic cutters.

Initially considered as a point of reference for cutting systems in the textile applications, the Rasor® products are nowadays widely used in other fields: chemical, automotive, nautical and sport sectors and in furniture manufacturing.

Rasor® can rely on the professional continuity of three generations, thanks to the precious support of the promoting partner, to his passion, dedication and great experience of seventy years.

The main characteristic of Rasor® is that each working phase, starting from the manufacturing of the product up to its packing and delivery, is carried out in Rasor® premises by qualified operators who have professionally grown up following the spirit of the company and of its founders. This ensures the high quality which Rasor® has always considered as essential since the beginning of its activity.

Following the innovative spirit mentioned above, our company is constantly focused on the improvement of the product quality, on the study and development of new materials and technologies.

ACKNOWLEDGMENT

Dear Customer,

thank you for choosing a Rasor® Elettromeccanica S.r.l. product.

Rasor® has been a reference point in the field of cutting systems in the textile, clothing, furniture, tailoring, sport, chemical, automotive, nautical and insulating material sectors for years. Its production has been always synonymous with reliability attested by many of satisfied customers.

Rasor® quality system supervises all the company activities in order to provide the Customer with a service that meets its needs and expectations in terms of product quality, delivery reliability and stock of finished products.

All the parts of the devices have been planned and produced to guarantee an optimum performance. In order to keep the high quality level and the long reliability of the Rasor® products, it is recommended using only original spare parts and to contact the head office for any maintenance work.

1. GENERAL SAFETY RULES



This manual is an integral part of battery scissors TT703 TurfTrimmer and must be carefully read before using it, since it gives important indications with regards to its safe installation, use and maintenance. Keep it with care.



Before using battery scissors TT703 TurfTrimmer, read carefully the following general safety rules.

- **PACKAGING.**

After taking off the packaging make sure that the battery scissors are intact. In case of doubt do not use them and contact an authorized service centre. Do not leave pieces of packaging (plastic bags, foam polystyrene, boxes, etc.) within the reach of children or disabled persons, since they are potential sources of danger.

- **AVOID DANGEROUS ENVIRONMENTS.**

Prevent the battery scissors TT703 TurfTrimmer components from coming in contact with damp or wet surfaces.

- **KEEP CHILDREN AWAY.**

Unauthorized persons, in particular children, must be kept away from the working area.

- **KEEP THE WORKING AREA ALWAYS IN ORDER.**

The workplace must always be kept in order and well lightened; liquids or oil traces must not be present.

- **ALWAYS USE BATTERY SCISSORS TT703 TurfTrimmer PROPERLY.**

Use the battery scissors only to carry out the works they have been designed for; do not use them improperly.

- **OBSERVE THE USE OF THE TOOLS.**

Do not cut excessively thick materials and always check blade conditions.

- **AVOID ACCIDENTAL STARTINGS.**

Before starting battery scissors TT703 TurfTrimmer, make sure that everything is installed properly.

- **CLOTHING.**

Do not use large clothes or accessories that might get stuck in the moving parts.

- **GOGGLES AND PROTECTIVE METAL MESH GLOVES.**

Always use goggles, protective metal mesh gloves approved by Rasor® during use and maintenance operations (according to UNI EN 388:2004 standard).

- **SPARE PARTS.**

During maintenance and replacement operations use only original spare parts. Blade maintenance must be only performed by Rasor® technicians.

- **INSTALLATION.**

Any installation that is not in conformity with these specifications could jeopardize your safety and cancels the warranty.

Informative letter

The installer and the maintenance man must know the content of this manual. Although the main features of the equipment described in this manual are not subject to change, **Rasor® Elettromeccanica S.r.l.** reserves the right to modify the components, details and accessories it deems necessary to improve the product or to meet manufacturing or commercial requirements at any time and without being obliged to update this manual immediately.

EN

4



WARNING



ALL RIGHTS ARE RESERVED ACCORDING TO THE INTERNATIONAL COPYRIGHT CONVENTIONS,

The reproduction of any part of this manual, in any form, is forbidden without the prior written authorization of Rasor® Elettromeccanica S.r.l.

The content of this guide can be modified without prior notice. Great care has been taken in collecting and checking the documentation contained in this manual to make it as complete and comprehensible as possible.

Nothing contained in this manual can be considered as a warranty, either expressed or implied - including, not in a restrictive way, the suitability warranty for any special purpose. Nothing contained in this manual can be interpreted as a modification or confirmation of the terms of any purchase contract.

Rasor® Elettromeccanica S.r.l. products have not been conceived to work in areas at risk of explosions and at high risk of fire and they cannot cut wet or damp materials. Moreover, they cannot work in case of rain.

In case of damage or malfunction, battery scissors TT703 TurfTrimmer must not be used until the Customer Care Technical Service has repaired them.

Customer Care Technical Service



dal 1946

For any information, please contact
RASOR® ELETTROMECCANICA S.r.l.
Via G. Mattei 41/43-20044 ARESE (MI)-ITALY
Ph: +39.02.66221231
info@rasor-cutters.com
www.rasor-cutters.com

WARNING



The original configuration of the battery scissors must not be changed at all. On receiving them, make sure the supply corresponds to what has been ordered. In case of non-compliance immediately inform Rasor®. Also make sure the scissors have not been damaged during transport.



dal 1946

22. TRANSPORT AND PACKING

The scissors are delivered in a carrying case with the battery and the charger. The code of the ordered product and its serial number are indicated outside the package (see picture 1). The following accessories are contained in a bag inside the carrying case:

- 1) 4-edge blade
- 2) Grease tube
- 3) Pin for blade assembly/disassembly
- 4) Butterfly key for blade nut disassembly

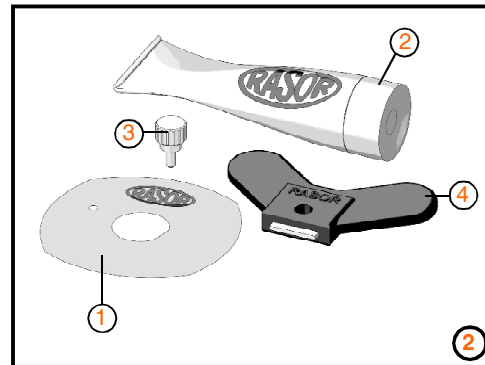
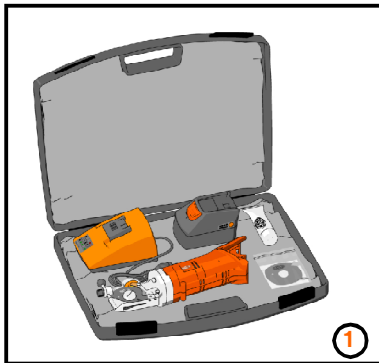

EN
5

3. PLATE DATA

The manufacturer's identification and EC STANDARD 2006/42/EC conformity plate (see picture below) is located on the front part of the battery scissors.

The plate must not be removed at all, even if the equipment is resold. Always refer to the serial number (written on the plate itself) when contacting the manufacturer.

Several safety warnings are printed on a card which is applied to the battery scissors; such warnings must be strictly followed by everyone dealing with the equipment. **The company is not to be held responsible for damage to property or accidents to people which might occur if the above-mentioned warnings are not observed. In such a case, the operator is the only person responsible.**

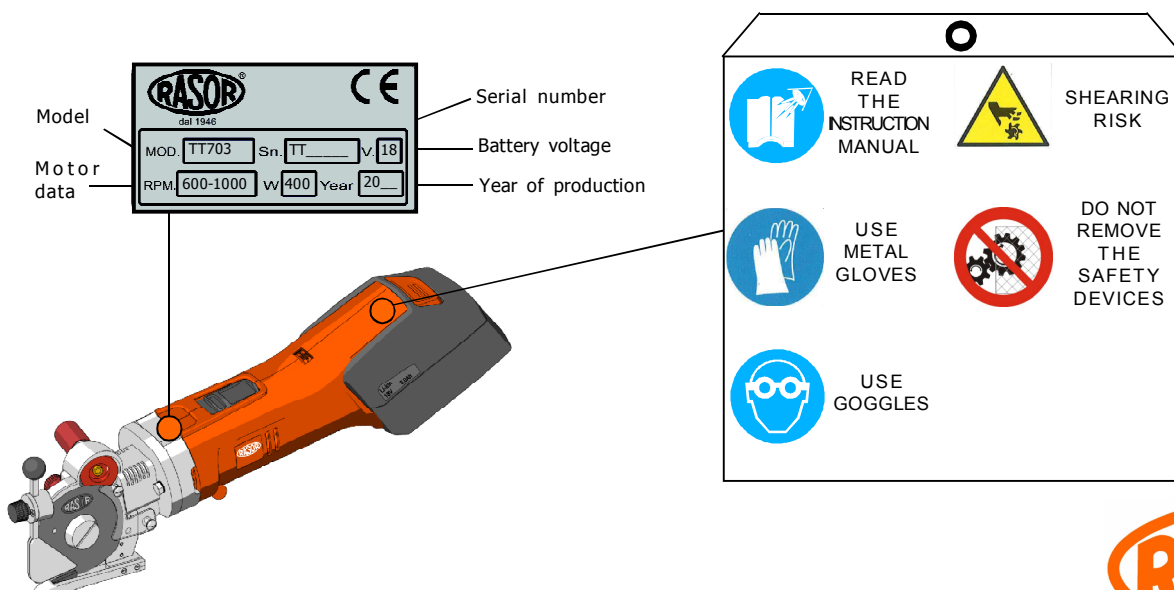

RASOR[®]
dal 1946

4. PRODUCT DESCRIPTION

EN
6

This manual describes battery scissors model TT703 TurfTrimmer which are used in order to cut synthetic (sports and ornamental) grass and surfaces (e.g. playgrounds). The battery scissors are effective on all types of grass, with any kind of fibre, with classical or thermowelded backings. Thanks to a system where the blade is always in contact with the counterblade, the cut is precise, clean and with no tearing. A system opening the turf allows the scissors to cut only the backing leaving the fibres untouched.

One special feature of battery scissors TT703 TurfTrimmer is their ability to sharpen the blade in each moment, without disassembling it, by means of a grinding wheel mounted on the scissors. After carrying out this operation, it is possible to immediately start cutting again. A high power motor, perfectly balanced, with a high number of revolutions and totally free of maintenance, reduces the vibrations to the minimum. For this reason the battery scissors comply with European Directive No. 2002/44/EC concerning the risks deriving from mechanical vibrations. The mechanical parts are made of high-quality steel, bronze and aluminium and require lubrication after several working hours.

Device components

1	Sliding switch	9	Knob to adjust the fibre opening system
2	Battery Li-Ion 18V with LED	10	Motor support
3	Plastic motor casing	11	Back protection guard
4	Steel foot	12	Grass fibre opening system
5	HSS 4-edge blade	13	Carbide counterblade
6	Greaser	14	Yarn-stop deflector
7	Emery grinding wheel	15	Blade speed regulator
8	Sharpening button	16	Button for battery disconnection

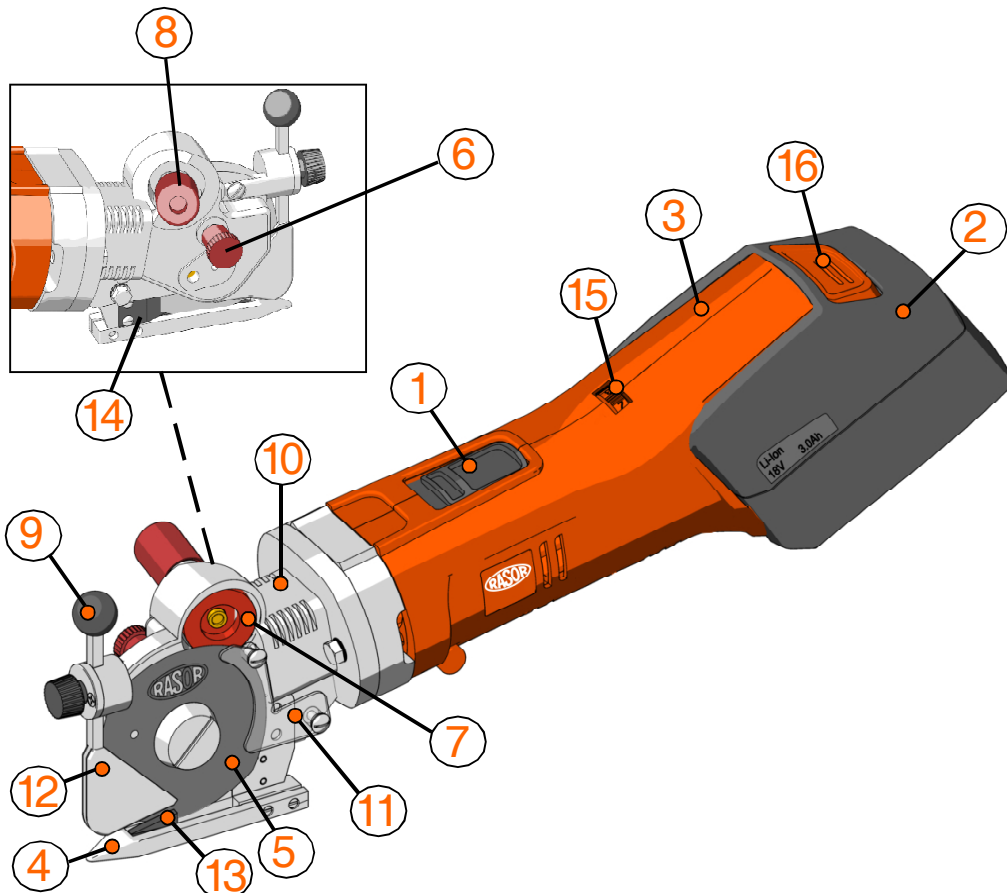

RASOR[®]

dal 1946

5. TECHNICAL FEATURES

Battery scissors TT703 TurfTrimmer features	
Blade diameter	70 mm with carbide counterblade
Blade supplied	70SHSS, HSS steel 4-edges blade
Blade speed	600-1000 revolutions/min, adjustable
Cutting working depth	20 mm
Motor power	DC 18 V - 400 W
Battery	Li-Ion 18 V, 6.0 Ah with LED indicator
Weight (with battery)	1900 g
Total weight (with package)	4400 g
Minimum luminosity for working operations	LUX 200
Vibrations at the start up	< 2.5 m/s ²
Temperature	0 ~ 55°C
Humidity	10 ~ 95% without condensate

Features of the available blades	
70SHSS	HSS steel 4-edge blade Ø 70 mm
70EHSS	HSS steel 6-edge blade Ø 70 mm
70SHSSTF	Teflon coated HSS steel 4-4dge blade Ø 70 mm
70EHSS	Teflon coated HSS steel 6-edge blade Ø 70 mm
70DHSS	HSS steel 10-edge blade Ø 70 mm
70DHSSTF	Teflon coated HSS steel 10-edge blade Ø 70 mm

EN
7

The technical data is only indicative and it can be changed without notice

6. NOISE LEVEL

The maximum acoustic pressure level emitted by battery scissors TT703 TurfTrimmer is about 60 dB (A). Noise tests have been carried out in compliance with Standard UNI EN ISO 11202:2010. The device noise levels, measured at different distances (without any sound wave filtering system), vary in the extent of few db (A).

NOTE

It is advisable for battery scissors TT703 TurfTrimmer owners to verify the compliance with the standard concerning safety of workers: Italian legislative decree 81/08. The use of ear protecting devices is compulsory.

7. FIELD OF APPLICATIONS

Battery scissors TT703 TurfTrimmer have been designed, manufactured and assembled to cut every kind of synthetic grass and sports surfaces by means of rotary blades.

This equipment must not work:

- in areas prone to explosions;
- in presence of fine dust or corrosive gases;
- to cut plastic materials other than synthetic grass, metal and wooden materials.

It is forbidden to use battery scissors TT703 TurfTrimmer for purposes different from the above-mentioned ones.



dal 1946

8. USE WARNINGS

We recommend following the indications below in order to always work in safety conditions.

EN
8

- All the operations must be carried out complying strictly with the safety rules of the country where the device is sold.
- It is **STRICTLY FORBIDDEN** to smoke during the installation or adjustment operations of the battery scissors.
- The Customer undertakes to comply with and make his staff observe all the rules and regulations in force concerning safety, prevention of accidents and health in the work place. Therefore, the Customer assumes the responsibility to strictly follow all the rules and regulations in force, as well as the special provisions in force in sport and public installations the Customer declares to know after receiving all the relative necessary pieces of information.
- **The battery scissors work also without their safety protective device. This protective device must NEVER be removed.**
- Always check the resistance of the material to be cut and the kind of blade which is being used.
- The Customer shall equip his own personnel with all the individual safety protections for the execution of the works, as well as with the ones which might be prescribed by the Manufacturer due to specific danger conditions of the plant or of the area where the personnel must work.
- Only one operator must use the battery scissors always standing behind the guide handle. Do not make any adjustment while the blade is working.
- It is allowed to assemble battery scissors TT703 TurfTrimmer on machines O.E.M. on condition that their original structure is not modified. Otherwise, the intervention must be certified by Rasor®.

9. RESIDUAL RISKS

Even though the battery scissors are safe, operators must pay attention to preserve their and other people's safety.

- ⊗ At the end of the working operations, the metallic components could be very hot.
- ⊗ The cutting blade can work even when the protective device is disassembled.



dal 1946

10. RULES FOR THE CARE OF THE LITHIUM-ION BATTERIES

The following rules should be noted when caring for your lithium-ion batteries if you want to maintain the performance of the energy store for as long as possible:

- The first charge is crucial. Fully charge the battery before using it for the first time.
- Each battery only has a limited number of charge cycles. Don't therefore recharge the battery at every opportunity. Instead use it until it is almost flat (10...20% of charge). Depending on loading, the high-quality, 6 Ah capacity battery cells can be charged up to 2,000 times. Assuming 250 days are worked a year and that the batteries are charged daily, this corresponds to a battery life of 8 years.
- If the battery is discharged below its nominal voltage, this can trigger processes which damage or destroy the battery. The batteries are therefore fitted with electronics which warn the user and shut down the device before total discharge can take place.
- Frequent overcharging can also permanently damage the battery. The charger therefore automatically finishes the charging process as soon as the battery is fully charged. Do not attempt to force more charge into the batteries by unplugging and reconnecting the charger. Such action will not produce a higher charge - it will only damage the batteries.
- Charging should generally only be undertaken at room temperature (around 18 - 21 degrees). Avoid charging a cold battery as it damages the cells. Always warm the battery up to room temperature before charging, especially when it is cold outdoors in winter.
- High temperatures also damage the battery. Never leave the battery, and preferably not the entire tool box, in the car or direct sunlight on hot sunny days. At temperatures above 60 degrees Celsius, the Li-ion battery permanently loses capacity.
- Lithium-ion batteries shouldn't be stored flat or fully charged for long periods. Extensive testing has found a capacity of 40...50 % and low temperatures (but not below 0°C) to be optimum for storage. Ideally they should be kept at 5°C to 10°C. Recharging is needed at least every 12 months as the batteries will self-discharge.
- A battery which is not being used should be stored in a cool but not cold place. Even when not being used, batteries lose energy. The Li-ion battery loses 3...5% of its charge a month.
- If a lithium-ion battery is not used for a long period, it should be recharged after 12 months at the latest otherwise it will be irreparably damaged.
- Old, used batteries must of course be disposed of in an environmentally friendly manner.

11. USE

To use the battery scissors manually, proceed as follows:

- 1) Release the battery (if it is charged) from the charger as described at paragraph 13;
- 2) Connect the battery to the motor and fix it following the slots on the battery;
- 3) Prepare the synthetic grass to cut;
- 4) Put the synthetic turf on the cutting foot (see picture 3);
- 5) Adjust the fibre opening system according to the thickness of the turf (see picture 4).
A low adjustment ensures that a minimum quantity of fibres is cut;
- 6) Let the switch slide forward in order to start the scissors;
- 7) Push the battery scissors in the desired direction by tightening the synthetic turf as much as possible;
- 8) It is also possible to cut the overturned turf (see picture 5).

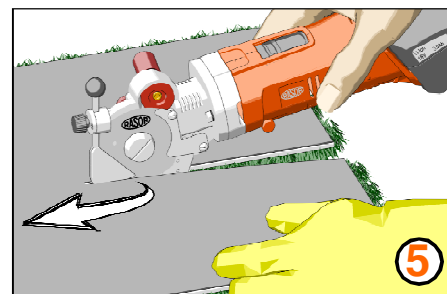
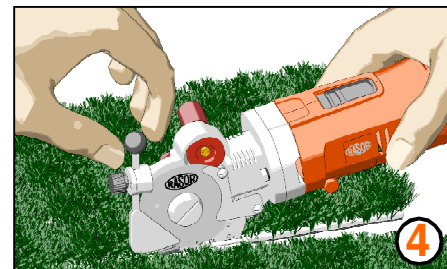
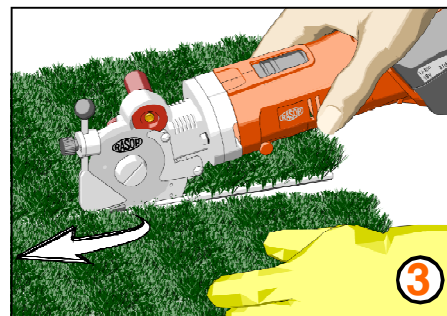

NOTE

The thrust on the battery scissors must be as uniform as possible.

12. SPEED REGULATION

The scissors TT703 TurfTrimmer have a regulator for 6 speed levels (see picture 6). It is possible to change the speed also when the scissors are working. The blade speed can go from 600 rpm (Pos. "1") to 1000 rpm. The "standard" position is position "2" for most materials. It is advisable to use low speed levels for hard, gummy, plastic or adhesive materials. High speed levels are instead suggested for natural fibers and simple fabrics or when a raised speed is needed.

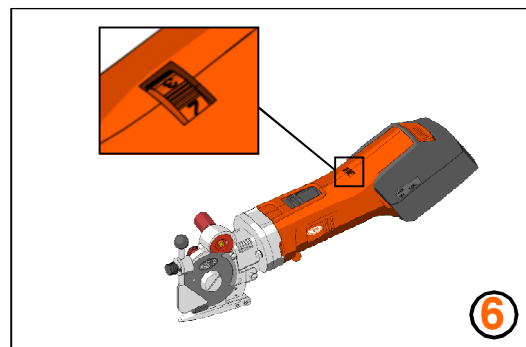

WARNING



Using the battery scissors TT703 TurfTrimmer with high blade speed accelerates the wear of the moving parts such as blade, counterblade and gear pair. The high blade speed determines also a faster loss of battery charge.

RASOR[®]

dal 1946

13. BATTERY CHARGING

When the battery is discharged, it is necessary to charge it using exclusively the charger provided with the tool.

WARNING 

Always check if the charger voltage corresponds to the network voltage of the country where the scissors are used.

WARNING 

Do NOT use chargers that are different from the one provided (FEIN ALG80 - 50Hz/230V - 10,8-18V).

Release the battery from the motor by pushing the orange button, then insert it in the charger following the instructions written on the manual provided with the charger.

Never use batteries that are different from the one provided (FEIN 18V - 6.0 Ah - 54Wh). It is possible to check the charging status by means of the LED lights placed on the charger (see picture 7).

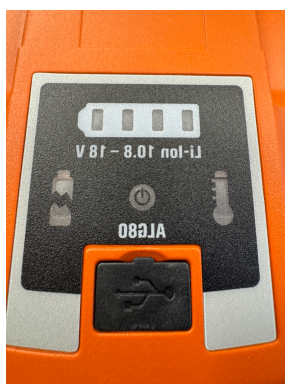

LED indicator		Meaning
1	continuous green light	The battery charger is ready for operation; mains voltage is given
2	green flashing light	The rapid charging is active
3	continuous green light	The rapid charging is completed.
4	continuous red light	<p>Charging not possible due to the following possible reasons:</p> <ul style="list-style-type: none"> - Contacts contaminated. Improvement measure: Clean the contacts by inserting and removing the battery several times. - The battery is defective. Improvement measure: Replace the battery!
5	continuous yellow light	The battery temperature is not within the charge-temperature range of 0 °C to +45 °C. The rapid charging procedure starts as soon as the battery reaches the allowable charge-temperature range.

Using the standard charger CH22 (provided with the scissors), the time needed for a complete charge is about 90 minutes.

14. BLADE SHARPENING

After many hours of a continuative use of the battery scissors or if they are not able to cut anymore, it is necessary to sharp the blade. To carry out this operation, start the blade and press sharpening button "1" for 3-4 seconds (as shown in picture 8). Repeat this operation 2-3 times.

EN
12

If the sharpening process should be ineffective, check the wear of the emery grinding wheel "2" (see picture 8). If wheel "2" is too worn or dirty, replace it by removing the blade with the proper tool.

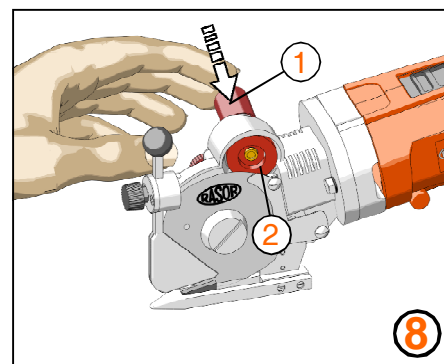

15. LUBRICATION

Every 3-4 days of use, it is necessary to lubricate the pair of gears. To carry out this operation, remove protective plug "A" located on the head of the battery scissors and fill it with the supplied lubricating grease.

Screw plug "A" again few turns. Screw plug "A" some turns every 2-3 working hours (see picture 9).

Fill the plug again, once it has been tightened.

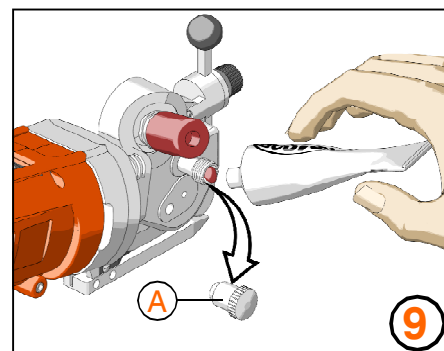

WARNING



The blade must never be dirty with grease or oil.

RASOR[®]

dal 1946

16. BLADE REPLACEMENT

If the blade is no more able to cut (even after repeating the sharpening operation several times), it is necessary to replace it. In order to carry out this operation, use butterfly wrench "1" and pin "3" locking the blade (shown in picture 10).

In order to replace the blade, proceed as follows:

- 1) Use some protective gloves in compliance with Italian Legislative Decree 81/08;
- 2) Remove the safety back fixed protection "A" (see picture 11), by unscrewing the two slotted screws "C" by means of a screwdriver (not supplied by the manufacturer) as shown in picture 12.
Remove the fibre opening device "B" (see picture 13) by unscrewing screw "D" as shown in picture 12.
- 3) Insert drift "3" (see picture 13) into hole "E" in order to lock the blade (the hole in the blade must correspond to the hole in the structure).
- 4) Use butterfly wrench "1" in order to unscrew nut "F" (see picture 13) and remove blade "G" (see picture 14).
- 5) Replace the worn blade with the new one "2", being careful to center the blade on the ring gear, in the correct position, and remember to assemble it with the side with the writing Rasor positioned towards the external side of the battery scissors.
- 6) Assemble all the components again and carry out some cutting and sharpening tests.

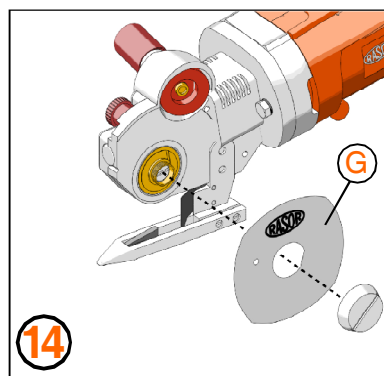
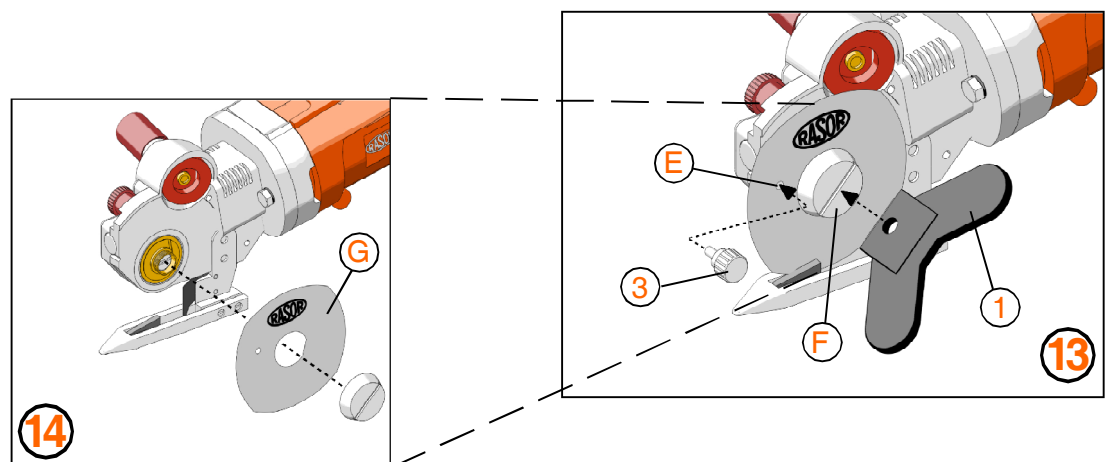
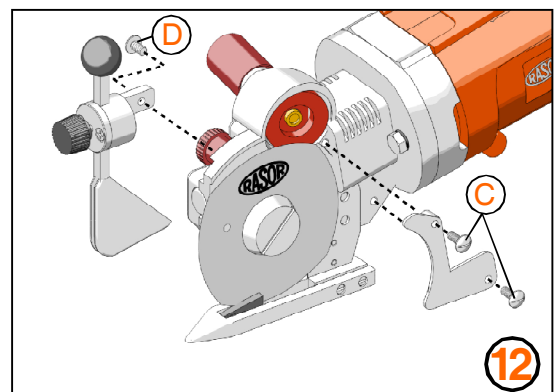
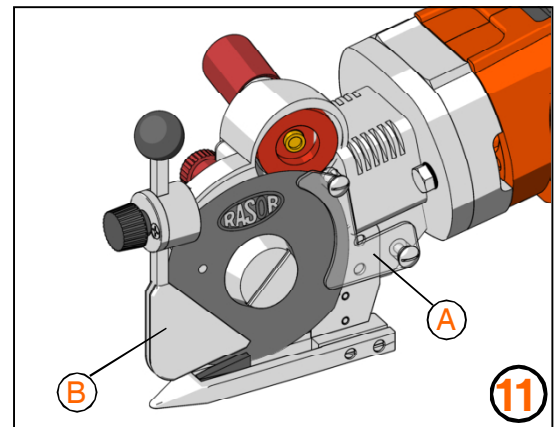
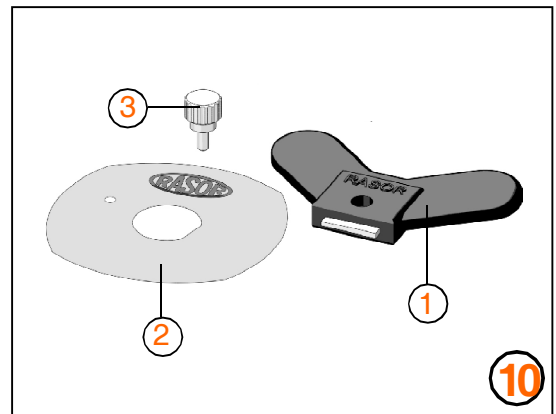

17. TROUBLESHOOTING

✘ PROBLEM

➔ SOLUTION

The material is not cut or it gets stuck between the blade and the counterblade

Check that blade and counterblade contact with each other

Check the kind of material

Sharpen the blade

Check the material thickness

Make sure that the motor turns correctly

Reduce the feeding speed

Check the counterblade integrity

Carry out the lubrication

The battery scissors are noisy

Disassemble the blade and remove the material residues

Check the wear of the pair of gears

The scissors start slowly, work intermittently or do not start

Check the battery charge level by means of the LED indicator

Check if the battery has been correctly inserted

Check the plastic joint between motor and cutting part

18. SPARE PARTS / EXPLODED VIEW

CODE	DESCRIPTION	CODE	DESCRIPTION	CODE	DESCRIPTION	CODE	DESCRIPTION
BA001	MOTOR CASING OF PLASTIC	F7009	SUPPORT FIXING KNOB	F7038	RING GEAR BEARING	70SHSS	QUADRANGULAR BLADE Ø 70 mm, H.S.S. STEEL
BA002	SLIDING SWITCH	F7011	CYLINDRICAL SUPPORT	F7039CPL	COMPLETE RING GEAR	SW108600	EMERY GRINDING WHEEL: MEDIUM GRAIN
BA003	MAGNET MOTOR WITH COUPLING POINTS	F7012	CLOSING DISK	F7042	BLADE FIXING RING NUT	SW1086CPL	COMPLETE EMERY GRINDING WHEEL UNIT
BA004	MOTOR FLANGE FASTENING SCREW	F7013	DISK FASTENING SCREW	F7044	BACK PROTECTION GUARD FASTENING SCREW	SW108700	EMERY GRINDING WHEEL PIN
BA005	MOTOR CASING FASTENING SCREW	F7014	CYLINDRICAL SUPPORT FASTENING SCREW	F7045	BACK PROTECTION GUARD	SW108800	EMERY GRINDING WHEEL SPRING Ø 11 mm
BA006	ELECTRONIC CONTROL CIRCUIT	F7026C	TT703 COMPLETE MOTOR SUPPORT	F7045CPL	BACK PROTECTION SET	SW108900	SCREWED BUSH
BA008	LOCKING SPRING	F7027	PLASTIC JOINT	F7049	PLATE LOCKING THE EDGE	SW109000	EMERY GRINDING WHEEL SPRING Ø 6 mm
BA010	TT703 COMPLETE MOTOR	F7028	CLOSING RING	F7050	PLATE LOCKING THE EDGE FASTENING SCREW	SW109200	EMERY GRINDING WHEEL CAP FASTENING SCREW
BAT18	BATTERY Li-Ion 18V, 6.0 Ah WITH LED	F7029	WORM SCREW BEARING mm 10x22x6	F7053	WELD FOOT	SW109300	STEEL WASHER
CH22	CHARGER	F7030	WORM SCREW - MOD. 1	F7053CPL	COMPLETE WELD FOOT	T104700	GREASER CAP
F5057	DRIFT LOCKING THE BLADE	F7030CPL	COMPLETE WORM SCREW - MOD. 1	F7054	FOOT FASTENING SCREW	T104800	GREASER
F5059	BLADE ASSEMBLY/DISASSEMBLY WRENCH	F7031	ANTI-FRICTION BUSHING	F7054/1	TOOTHED WASHER	T105200	MOTOR SUPPORT FASTENING BOLT
F7006	EMERY GRINDING WHEEL CAP	F7032	SNAP RING	F7055	WIDIA COUNTERBLADE WITH SPRING	T105300	SPLIT WASHER
F7007	FIBRE OPENING SYSTEM	F7033	CORRUGATED THRUST WASHER	F7056	COUNTERBLADE FASTENING SCREW	T106000	RING GEAR LEFT FASTENING SCREW
F7007CPL	COMPLETE FIBRE OPENING SYSTEM	F7036	THRUST WASHER	F7061	SUB-BLADE RING	T107900	LUBRICATING GREASE
F7008	BALL FOR SUPPORT	F7037	RING GEAR	FRN70B	TT703 COMPLETE ACCESSORIES SET		

OPTIONAL ACCESSORIES

CODE	DESCRIPTION
BAT18	BATTERY Li-Ion [®] 18V, 6.0 Ah WITH LED
CH22	STANDARD CHARGER (230 V)

THE COMPLETE EXPLODED VIEW OF THE SPARE PARTS IT'S AVAILABLE AT:

WWW.RASOR-CUTTERS.COM/EN/PRODOTTI/TT703/



dal 1946

WARRANTY

Razor® Elettromeccanica S.r.l. battery scissors have a 12 month warranty from the date indicated on the last page of this manual, except in case of different written agreements.

The warranty covers all manufacturing and material defects. Replacement and repair operations are covered only if carried out by our company and at our workshop. If in-warranty goods need to be repaired, **the customer must always send the complete machine to Razor®.**

Single units will not be repaired under warranty.

The material to be repaired must be sent CARRIAGE FREE.

Once the equipment has been repaired, it will be sent CARRIAGE FORWARD to the customer.

The warranty covers neither technicians' intervention on the site where the battery scissors are used nor their disassembly.

If for practical reasons, one of our technicians is sent to the premises, the customer will be charged the costs plus the travelling expenses.

The warranty does not include:

- ☞ failure caused by wrong use or assembly,
- ☞ failure caused by external agents,
- ☞ failure caused by lack of maintenance or negligence;
- ☞ blades and parts subject to wear.

WARRANTY FORFEITURE:

- ☞ In case of arrearage or other breaches of contract,
- ☞ Whenever changes or repairs are carried out on our battery scissors without our prior authorization,
- ☞ Whenever the serial number is tampered with or cancelled,
- ☞ Whenever the damage is caused by improper use, bad treatment, bumps, falls and other causes not due to normal working conditions,
- ☞ Whenever the unit seems tampered with, dismantled or previously repaired by unauthorized staff,
- ☞ In case the battery scissors are used for purposes that are different from the ones described in this manual.
- ☞ In case non-original Razor® spare parts are installed.

All repair operations carried out under warranty do not interrupt its duration.

All disputes will be settled in the court of justice of Milan (Italy).

We thank you in advance for the attention you will pay to this manual and we invite you to inform us of any change you deem necessary to improve it and make it more complete.

CERTIFICATION FOR LITHIUM BATTERY

TRANSPORTATION CERTIFICATE

Concerning the transport according to the dangerous goods regulations of the different transport modes as in force since January, 1st 2003 and changes effective from 2013

WE HEREWITH CERTIFY THAT EACH BATTERY PACK IS OF THE TYPE PROVED TO MEET THE REQUIREMENTS OF EACH APPLICABLE TEST IN THE UN MANUAL OF TESTS AND CRITERIA, PART III, SUB-SECTION 38.3, Rev.5, Amend.1

CERTIFICATE / REPORT NO.: BU-2013-000402-UN	
No. UN / Shipping name:	UN 3480 LITHIUM BATTERY UN 3481 LITHIUM BATTERY (packed with equipment / contained in equipment)
Certified product:	Accumulator - Rechargeable LI-ION
Model designation:	5S2P ICR18650 HD2 (18V/6 Ah)
Article number:	B18A.165.01 / 16226-12GP
Certification holder:	C.&E. Fein GmbH Hans-Fein-Str. 81 D-73519 Schwäbisch-Gmünd - Germany

PERFORMED TESTS	RESULTS
38.3.4.1 Test 1: Altitude simulation	passed
38.3.4.2 Test 2: Thermal test	passed
38.3.4.3 Test 3: Vibration	passed
38.3.4.4 Test 4: Shock	passed
38.3.4.5 Test 5: External short circuit	passed
38.3.4.6 Test 6: Impact/Crush	not required for battery packs
38.3.4.7 Test 7: Overcharge	passed
38.3.4.8 Test 8: Forced discharge	not required for battery packs

► Watt-hour rating of the battery pack: 72,00Wh ◀

This lithiumion battery pack is **NOT RESTRICTED** and it is admitted to the **EASED TRANSPORTATION** (as without complying with the rules of the Dangerous Goods Regulation in full scale).

According to Packing Instruction 965 (UN3480) or 966/967 (UN3481), Section II – Excepted Lithium Ion Cells and Batteries - of the IATA-DGR and Special Instruction 188 of the ADR/RID, ADN, IMDG-Code. **FOR CARRIAGE BY AIRPLANE THE "LITHIUM BATTERY HANDLING LABEL" IS REQUIRED.**

In case of damaged batteries during transport/unpacking, please call the following 24/24h number: +49 (6132) 9829021.



Signature: Sven Bauer, CEO

RASOR ELETTROMECCANICA SRL

Via Giannetto Mattei 41/43

20044 ARESE (MI) - ITALY

ph. +39 02 66 22 12 31

info@rasor-cutters.com

www.rasor-cutters.com

FOLLOW US:

