



1946

PNEUMATIC CUTTING UNIT

FP-CROSS



USE AND MAINTENANCE INSTRUCTIONS

Please read this manual carefully before using the device and keep it safe with the product.

TRANSLATION OF ORIGINAL AND COMPLETE INSTRUCTIONS

MEANING OF WARNING AND DANGER SYMBOLS

Safety instructions, which must be followed to prevent physical harm, are identified by the following symbols:

CAUTION HAZARD



Indicates operations that can cause generic injuries or trigger malfunctions or damage to the equipment and/or materials if not carried out correctly; particular attention and adequate preparation are therefore required.

CAUTION ELECTRICAL HAZARD



Indicates operations that can cause electrical injuries or trigger malfunctions or damage to the equipment and/or materials if not carried out correctly; particular attention and adequate preparation are therefore required.

DO NOT



Indicates PROHIBITED operations.

EC - DECLARATION OF CONFORMITY

PRODUCT MANUFACTURED BY:
RASOR ELETTROMECCANICA SRL

Via Giannetto Mattei, 41/43 - 20044 Arese- (MI) - ITALY

Model: FP-CROSS

Rasor Elettromeccanica S.r.l. declares, under its own responsibility, that the aforementioned products, to which this declaration refers, comply with the Directives on the approximation of the laws of EEC member states relating to:

- Machinery 2006/42/EC;
- Electromagnetic Compatibility 2014/30/EU
- RoHS Directive 2011/65/EU
- CEI EN 62841-1 standard
- IEC 62841-2-2 standard

Milan, 15/03/2025



Mr Lorenzo Spinelli
CEO

INDEX

1 GENERAL INFORMATION	3
1.1 Important safety information	3
1.1.1 General warnings	3
1.2 Prohibitions	4
1.3 Handling and storage	4
1.4 Limits of use	4
1.5 Technical specifications	4
1.6 Noise	4
1.7 Vibrations	4
1.8 Limitation of liability	4
1.9 Identification data	4
1.10 Package contents	5
1.11 Description of the device	5
2 USE.....	6
2.1 O.E.M. installation	6
2.2 Air handling unit (optional)	7
3 MAINTENANCE	7
3.1 Blade sharpening	7
3.2 Lubrication	8
3.3 Replacing the blade	8
3.3.1 Available blades	9
3.4 Problems and possible causes/solutions	9
4 SPARE PARTS.....	10
5 DISPOSAL	10
5.1 Disposal at end of life	10
6 WARRANTY	11

GENERAL INFORMATION

1 GENERAL INFORMATION

1.1 Important safety information

1.1.1 General warnings

- The product user must store the following instructions carefully and follow them closely, as improper use of the device can harm people or damage the product or property, exempting **Rasor Elettromeccanica S.r.l.** from any liability.
- The following instructions must be kept with the product to which they refer and be stored in a place where users can access and view them.
- Reproduction, in whole or in part, of the illustrations or text given in these instructions is prohibited. **Rasor Elettromeccanica S.r.l.** reserves the right to amend the documentation without prior notice.



CAUTION HAZARD

The product must be started and used solely in compliance with all safety guidelines given in these instructions.

Failure to follow these instructions, or any product alteration not carried out by our authorised technicians, will void the warranty and relieve the manufacturer of any liability arising from harm to people, damage to property or to the product itself.



CAUTION HAZARD

Check that pneumatic and mechanical parts are in excellent working order before starting the device.

Use only original spare parts supplied by Rasor Elettromeccanica S.r.l.

Any required operation (maintenance or repair) must be carried out by qualified personnel after having cut the power supply, thus preventing accidental start-up which could cause harm to people or property. Switching the product off is not sufficient.

Users must follow the accident-prevention regulations in force in their country and must use adequate protection when using and maintaining the product.



CAUTION HAZARD

It is particularly important to keep the product out of reach of children and pets.

The product must be used indoors, away from wet and humidity.

The product must be cleaned solely with a dry cloth, after having disconnected it from the power source.

During normal work operations, do not wear loose-fitting clothing or accessories that may be a source of risk.

Metal mesh safety gloves and safety goggles must be worn during the normal work cycle.



CAUTION HAZARD

The cutting unit also works without a safety guard.

This guard must NEVER be removed.

Metal parts may be hot after use.



CAUTION HAZARD

Always pay attention to the position of the air hose before use as it may be cut or damaged by the blade.



CAUTION HAZARD

The **GRT-CROSS** cutting unit may be fitted to O.E.M. machinery provided its original structure is not altered in any way.

Any modifications must be certified by Rasor Elettromeccanica S.r.l.

1.2 Prohibitions



DO NOT

- The product and its pneumatic or mechanical connections **MUST NOT** be tampered with or modified.
- It is **FORBIDDEN** to remove parts of the product.
- It is **FORBIDDEN** to use the product in areas at risk of explosion and/or fire.

1.3 Handling and storage

The product must be stored in its original packaging and in a dry, covered location away from heat sources, dirt and humidity. The product can be stored between 0° and 55°C.

1.4 Limits of use

All Rasor Elettromeccanica products are tested before being shipped to the customer to guarantee safe and long-lasting operation.

The product must be used solely for its intended purpose. Any other use is forbidden and constitutes a risk.

The product operates at a maximum temperature of 55°C.

1.5 Technical specifications

Model	FP-CROSS
Blade diameter	70 mm, with carbide fixed blade
Blade supplied	70EHSS, 6-sided, HSS Steel
Blade speed	1300 r.p.m.
Cutting capacity	20 mm
Power	380 W (at operating pressure)*
Operating pressure	max. 6 bar* (±1 bar) with lubricated air
Air consumption	9 l/sec*
Net weight	920 g
Total weight (with packaging)	1750 g
Sound pressure	72 dB*
Minimum brightness for use	200 LUX
Start-up vibration	<2.5 m/s ² *
Usage temperature	0 - 55°C
Usage humidity	10%-95% without condensation

* data shown refer to recommended operating pressure of 6 bar

1.6 Noise

The maximum sound pressure level emitted is approximately 70 dB. Airborne noise was detected in compliance with EN ISO 15744:2008. The noise levels emitted by the device at various detection distances (with no soundwave filtration system) vary by a few db.

1.7 Vibrations

The **FP-CROSS** cutting unit complies with Leg. Dec. 187 of 19/8/2005, which implements European Directive 2002/44/EC on the risks arising from mechanical vibration.

1.8 Limitation of liability

The manufacturer declines all liability for any damage and malfunctions arising from:

- failure to follow the instructions given in this manual
- repairs not carried out in a workmanlike manner (the use of non-original spare parts and accessories can adversely affect product operation)
- damage caused by arbitrary changes by the user or by unauthorised interventions
- failure to carry out maintenance as indicated
- power supply faults
- damage or defects caused by improper use
- use by untrained or unauthorised personnel
- damage or defects caused by failure to follow use and maintenance instructions.

1.9 Identification data

A laser nameplate (A) stating the product technical data is applied to the FP-CROSS. Ensure the nameplate has been applied to the product; if not, inform the manufacturer and/or retailer immediately. Devices without the laser nameplate must not be used, or the manufacturer's liability will be voided.

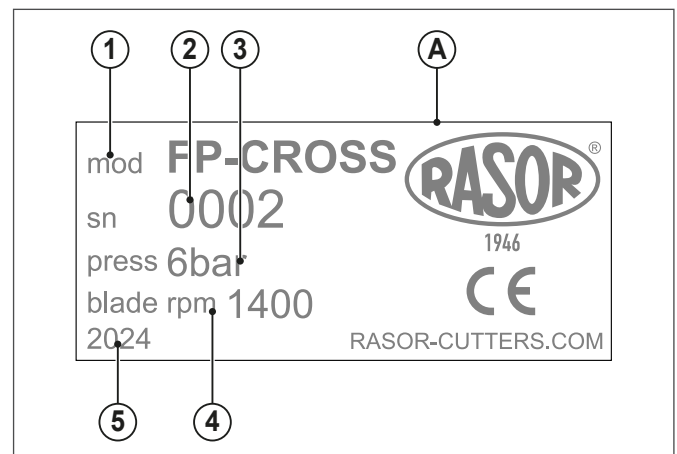

- 1 Model
- 2 Serial number
- 3 Operating pressure
- 4 Blade RPM
- 5 Year of manufacture

GENERAL INFORMATION

1.10 Package contents

The **FP-CROSS** is delivered with its accessories in a case (A). The product code and serial number are specified on the outer packaging.

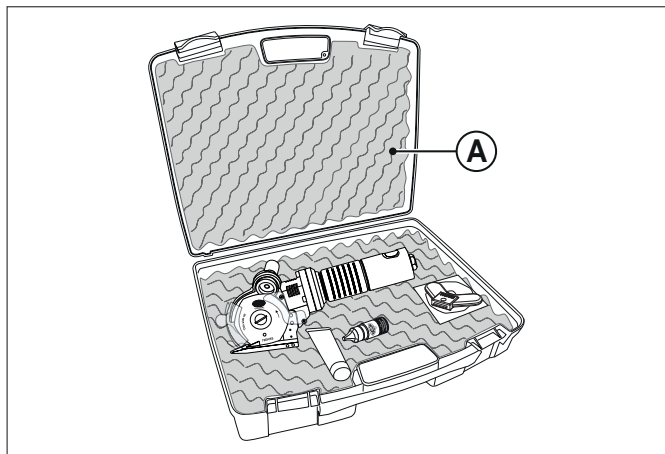

The following accessories are also included:

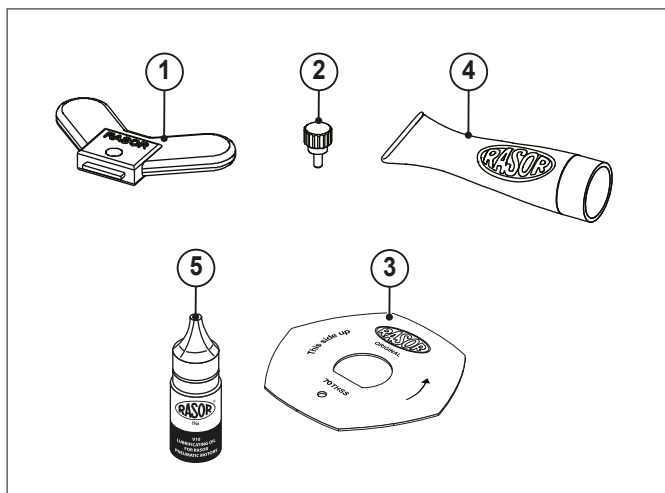

- 1 Butterfly key for removing/fitting blade
- 2 Blade assembly/disassembly punch
- 3 6-sided blade
- 4 Tube of lubricating grease
- 5 Lubricating oil 30 ml

1.11 Description of the device

The **FP-CROSS** cutting unit is designed to be fitted onto automatic machinery (e.g. spreaders, computerised cutters, etc.) using dedicated fittings (not included).

It enables continuous cutting, as well as cutting at variable heights if assembled in series.

It is particularly recommended for cross-cuts.

The **FP-CROSS** cutting unit is designed, built and assembled to cut fabrics and all kinds of materials – **EXCEPT FOR** metals, plastic and wood – using a rotary blade.

The equipment must not be used:

- in environments with explosive atmospheres;
- in the presence of fine dust or corrosive gases;
- for cutting plastic, metal or wood materials.

Any use of the FP-CROSS cutting unit for purposes other than those indicated above is prohibited and constitutes a hazard.

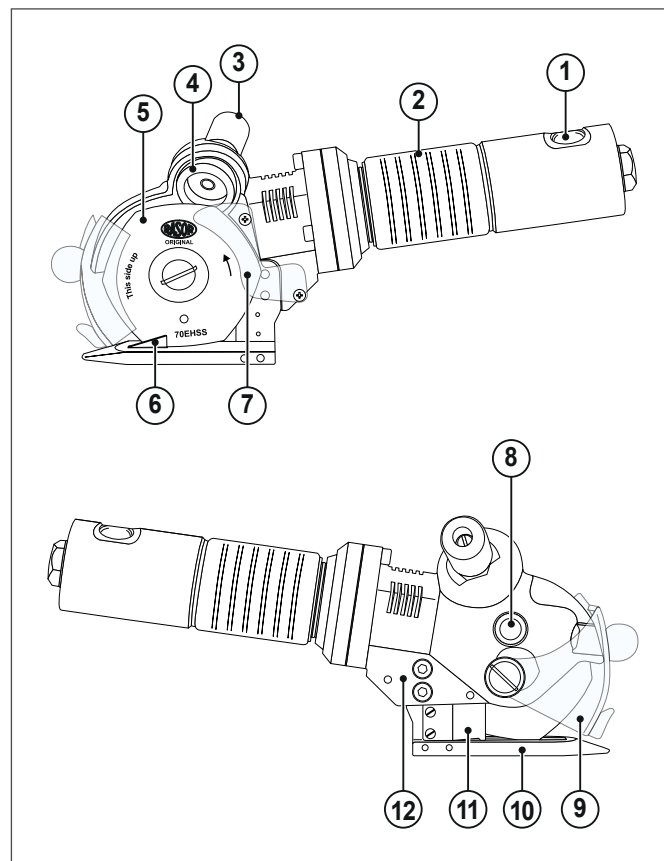

- | | |
|--------------------------------------|-----------------------------------------|
| 1 1/4" gas fitting for air connector | 7 Rear blade protection case (fixed) |
| 2 Pneumatic motor | 8 Greaser |
| 3 Sharpening button | 9 Front blade protection case (movable) |
| 4 Sharpener | 10 Base |
| 5 Polygonal blade | 11 Wire clip |
| 6 Carbide | 12 Motor support |

2 USE

2.1 O.E.M. installation

WARNINGS



For the pneumatic connection, use hoses with an interior diameter of at least 8 mm.

Proceed as follows to use the cutting unit:

- Install the FP-CROSS cutting unit onto the O.E.M. machine using a fitting system (1).

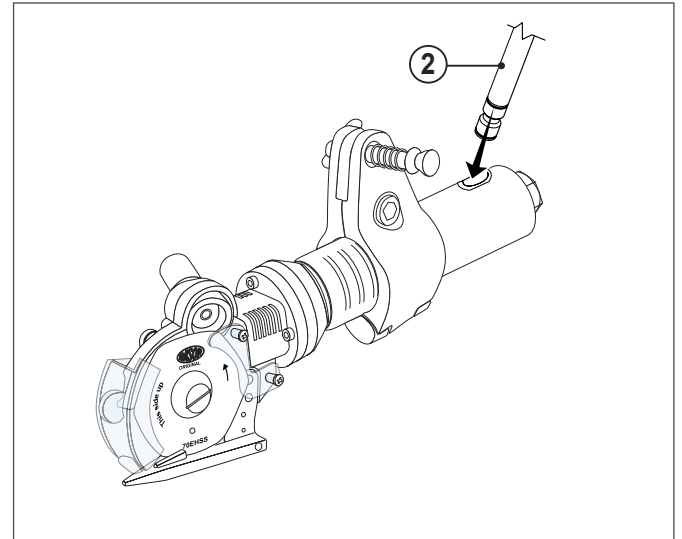
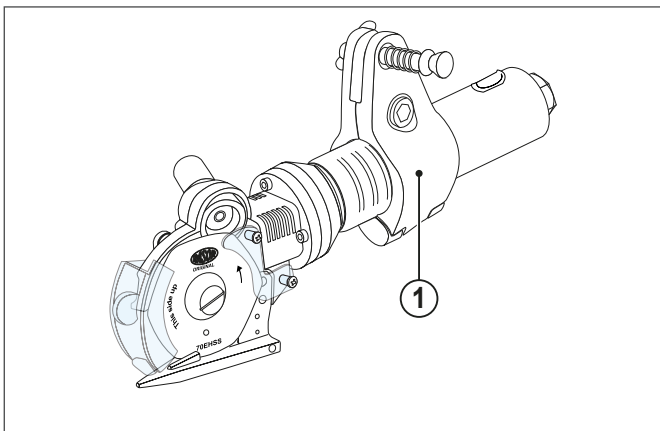

- Set the pressure gauge to 6 bar (optional);
- Position the material above the cutting base;
- Start the cutting unit, opening the air remotely;

The FP-CROSS cutting unit can work either stationary (moving the material) or moving while the material is kept stationary.

CAUTION HAZARD



Do not overtighten the fitting as this could deform the motor, causing it to malfunction.

- Attach the 1/42 GAS air connector (2). The air must be controlled remotely.

CAUTION HAZARD



The FP-CROSS cutting unit does not have an ON/OFF switch. The blade will begin to rotate as soon as the air is turned on.

MAINTENANCE

2.2 Air handling unit (optional)

The cutting unit must be supplied with dry lubricated air at a max pressure of 6 bar.

Rasor Elettromeccanica S.r.l. recommends using Rasor VG 10 special pneumatic oil.

Rasor Elettromeccanica S.r.l. makes available a "reducer filter with pressure gauge" already calibrated with the quantity of oil to be dispensed (optional).

It is made up of:

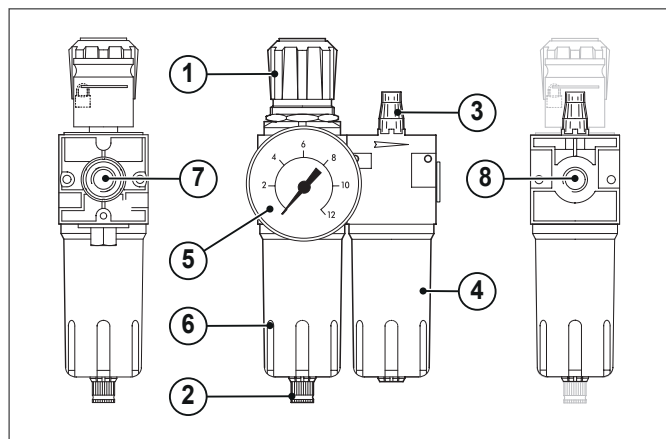

- 1 Pressure reducer
- 2 Condensate discharge valve
- 3 Drip-feed oiler
- 4 Oil reservoir
- 5 Pressure gauge
- 6 Condensate reservoir
- 7 Quick connect fitting from 1/4" GAS mains
- 8 Quick connect fitting to the 1/4" GAS cutting unit.

For use and maintenance instructions, see the leaflet provided with the filter.

3 MAINTENANCE

3.1 Blade sharpening

After several hours of continuous use, or if the cutting unit is no longer cutting as it should, sharpen the blade.



CAUTION

The sharpening switch can be pressed only once the front mobile protector has been lowered completely.

To sharpen the blade, start the cutter then press and hold the sharpening button (1) for 3-4 seconds.

Repeat 2-3 times.

If sharpening the blade is not effective, check the emery wheel (2) for wear.

If the emery wheel (2) is excessively worn or dirty, replace the wheel. To do this, first remove the blade using the appropriate tool.

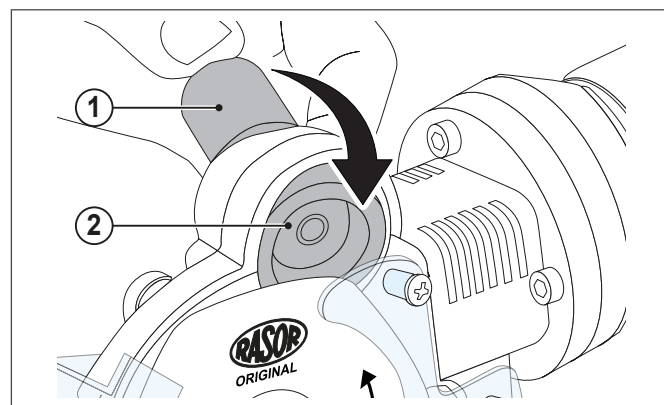

3.2 Lubrication

Lubricate the pair of gears every 2-3 days of use to keep them in good condition and reduce wear. To do this, remove the protective cap (1) on the cutting unit motor support and fill with the grease provided. Screw the cap (1) back into place.

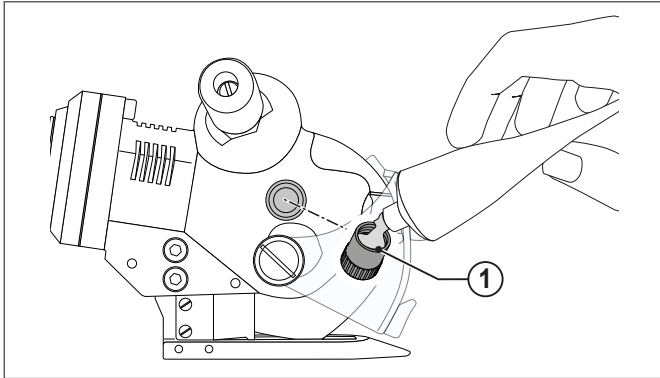

CAUTION

The blade must never be dirty with grease or oil, as this may damage the material being cut.

3.3 Replacing the blade

If the blade no longer cuts the material (even after repeated sharpening), replace it.

To do this you need the butterfly key (1) and blade-locking punch (2).

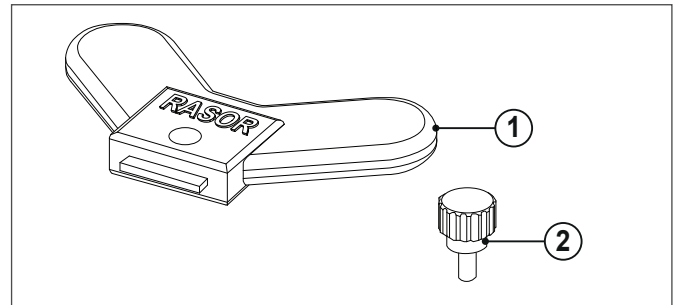

To replace the blade:

- 1 Disconnect the compressed air from the machine;
- 2 Wear protective gloves in accordance with Italian Legislative Decree 81/08;
- 3 Unscrew the screws (3) and (4) and remove the rear protection (A);
- 4 Unscrew the screw (5) and remove the blade protection case (B);

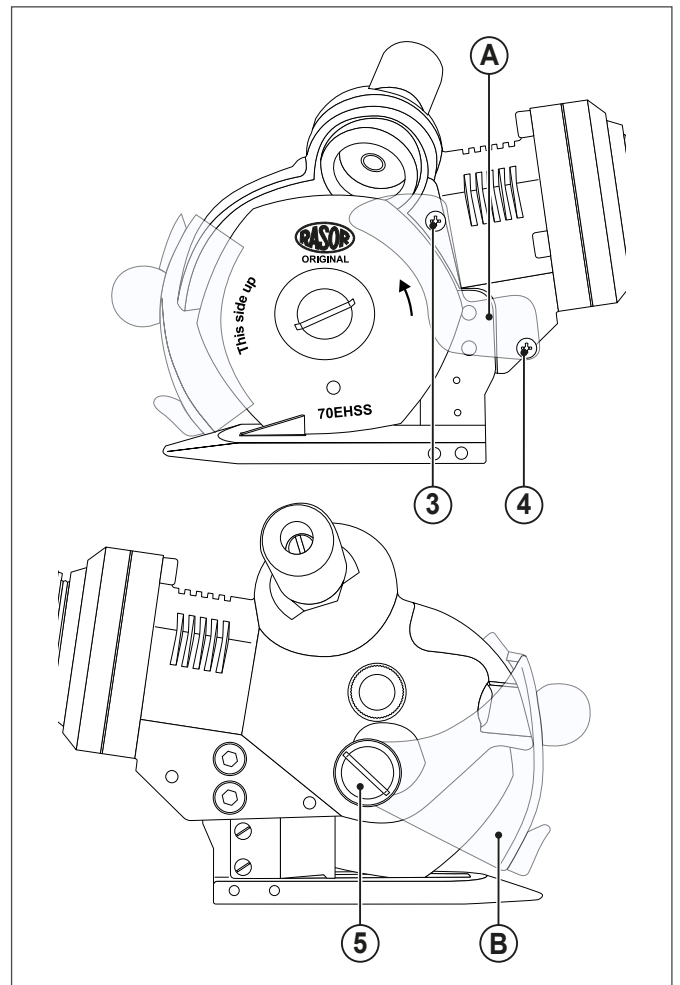

MAINTENANCE

- 5 Insert the punch (2) in the hole (C) to lock the blade, turning it until the holes line up;
- 6 Position the butterfly key (1) on the blade fixed ring nut (6), unscrew the ring nut and remove the blade (7);

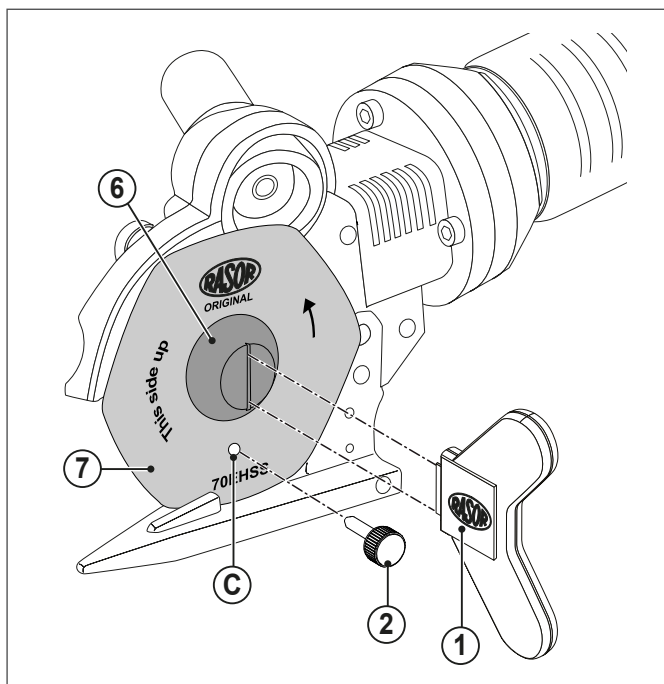

- 7 Replace the worn blade with a new one (8) of the same size and with the same specifications. Make sure the blade is centred on the gear in the correct position. Install the blade with the wording visible to the operator;

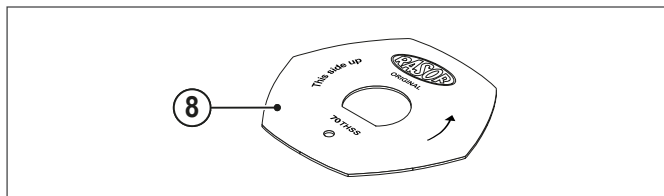

- 8 Refit all parts and test both cutting and sharpening.

3.3.1 Available blades

CODE	DESCRIPTION
70SHSS	4-sided Ø 70 mm HSS Steel blade
70EHSS	6-sided Ø 70 mm HSS Steel blade
70CHSS	Ø 70 mm EXTRA circular steel blade
70SHSSTF	4-sided Ø 70 mm Teflon®-coated HSS Steel blade
70EHSSTF	6-sided Ø 70 mm Teflon®-coated HSS Steel blade
70EMD	6-sided Ø 70 mm solid carbide blade (Widia®)
70DHSS	10-sided Ø 70 mm HSS Steel blade
70DHSSTN	10-sided Ø 70 mm Titanium-coated HSS Steel blade
70DHSSTF	10-sided Ø 70 mm Teflon®-coated HSS Steel blade

Technical data are indicative and subject to change without notice.

3.4 Problems and possible causes/solutions

ANOMALY	SOLUTION
The textile is not cut or gets stuck between the blade and the fixed blade	Check that the blade and fixed blade are touching and that there is no residual material on the fixed blade
	Check that the fixed blade is integral
	Check the type of textile
	Sharpen the blade
	Check the textile thickness
	Check compatibility between the blade and the fabric
	Check the turbine turns correctly
The cutting unit is noisy	Reduce the speed
	Lubricate
	Dismantle the blade and remove residual material
The cutting unit is slow to start, works on and off, or does not start	Check the silencer
	Check the gear pair for wear
	Check the pneumatic circuit is intact
	Set the operating pressure to 6 bar
	Check the inside diameter of the hoses and connections (min. Ø 8 mm)



WARNINGS

Contact the retailer for problems not included in this table

4 SPARE PARTS

WARNINGS



Use only original spare parts to replace faulty components. The warranty will be voided with immediate effect if non-original spare parts are installed.

When requesting spare parts, always state the exact model name and the device's serial number.

DO NOT



Using non-original spare parts can cause anomalous operation and harm people or property.

The warranty will be voided if non-original spare parts are installed.

WARNINGS



For an exploded diagram of spare parts with item codes, visit www.rasor-cutters.com

5 DISPOSAL

5.1 Disposal at end of life



CAUTION

Some parts of the product may contain polluting or hazardous substances that, if leaked, could harm the environment and human health.

Separate collection enables the decommissioned equipment to be properly recycled, treated and disposed of whilst preventing harm to the environment and to health and facilitating the reuse and/or recycling of the device's component materials.



CAUTION

Existing local regulations may impose heavy penalties for improper disposal of this product.

WARRANTY

6 WARRANTY

The Rasor® Elettromeccanica S.r.l. FP-CROSS cutting unit is covered by a 12-month warranty from the manufacture date, barring other written agreement.

The Rasor® Elettromeccanica S.r.l. FP-CROSS cutting unit is covered by a 12-month warranty from the manufacture date, barring other written agreement.

The warranty covers all material and manufacturing defects and envisages the replacement of spare parts or the repair of defective parts solely by us at our workshop.

If returning the product for repair, the customer must always send the complete cutting unit to Rasor®. Individual defective parts will not be accepted for repair under warranty.

Material for repair must be sent CARRIAGE PAID.

Once repaired, the device will be returned to the customer CARRIAGE FORWARD.

The warranty does not cover our technicians working on the customer's premises or dismantling the cutting unit.

If one of our technicians has to be sent out for practical reasons, labour will be charged at current rates plus travel expenses.

THE WARRANTY DOES NOT COVER:

- faults caused by incorrect use or assembly;
- faults caused by external agents;
- faults caused by neglect or poor maintenance;
- normal wear and tear on the blades and products;
- faults caused by untreated air (humid, unlubricated).

THE WARRANTY IS VOIDED:

- in the event of delinquency or other breach of contract;
- if repairs or changes are made to our cutting unit without our consent;
- if the serial number is tampered with or erased;
- if damage is caused by improper use or poor treatment, e.g. knocks, falls or other causes not attributable to normal operating conditions;
- if the device is dismantled, tampered with or repaired by personnel not authorised by Rasor® Elettromeccanica S.r.l.;
- if the cutting unit is used for purposes other than those stated in this manual;
- if parts other than Rasor® original spare parts are used.

Repairs made under warranty do not interrupt its duration.

The competent court for all disputes is the court of Milan.

RASOR ELETTROMECCANICA SRL

Via Giannetto Mattei 41/43

20044 Arese (MI) · Italy

ph. +39 02 66 22 12 31

info@rasor-cutters.com

www.rasor-cutters.com

FOLLOW US:

